

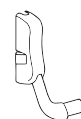

<b>CERTIFICAZIONI</b> CERTIFICATIONS .....	PAG.368
<b>MANIGLIONI ANTIPANICO</b> PANIC EXIT DEVICES .....	PAG.371
<b>COMANDI ESTERNI</b> OUTSIDE ACCESSORIES .....	PAG.374
<b>ACCESSORI PER MANIGLIONI ANTIPANICO</b> ACCESSORIES FOR PANIC EXIT DEVICES .....	PAG.377
<b>SCHEMI DI APPLICAZIONE PER PORTE AD UN'ANTA</b> SCHEMES FOR SINGLE DOORS .....	PAG.378
<b>SCHEMI DI APPLICAZIONE PER PORTE A DUE ANTE</b> SCHEMES FOR DOUBLE DOORS .....	PAG.379





SGQ N° 004 A PRD N° 004 B  
SGA N° 005 D PRS N° 082 C  
SGE N° 005 M ISP N° 046 E  
SCR N° 005 F ETS N° 003 D  
SSI N° 008 G EMAS N° 001 F

Member degli Accordi di Mutuo Riconoscimento EA, IAF e ILAC  
Signatory of EA, IAF and ILAC Mutual Recognition Agreements



## Certificazione di Prodotto Product Certification

Certificato N.  
Certificate No. **087AD/4**

ALL'AZIENDA / TO THE FIRM

**OMEC SERRATURE S.p.A.**

Via Caselli, 22  
25065 Lumezzane Pieve (BS) Italy

UNITÀ OPERATIVE / OPERATIVES UNITS

PER I SEGUENTI PRODOTTI / FOR THE FOLLOWING PRODUCTS

**DISPOSITIVI ANTIPANICO PER USCITE DI SICUREZZA AZIONATI  
MEDIANTE UNA BARRA ORIZZONTALE  
PANIC EXIT DEVICES**

CON DENOMINAZIONE COMMERCIALE / WITH TRADE NAME/S

**serie 6210**

art.i 6211, 6211DX, 6211SX, 6212, 6212DX, 6212SX, 6213, 6213DX, 6213SX,  
6211\*\*, 6211\*\*DX, 6211\*\*SX, 6212\*\*, 6212\*\*DX, 6212\*\*SX, 6213\*\*, 6213\*\*DX,  
6213\*\*SX, 1080017, 1080027, 1080037, 1080047, 1080057.

Con kit art.i 6040, 6040\*\*, 6041, 6041\*\*, 6032, 6032\*\*, 1080110, 1080111, 1080120,  
1080121, 1080130, 1080131, 1080140, 1080141, 1080150, 1080151.

Con barra orizzontale art.i 6005\*\*, 6006\*\*, 1080018, 1080028, 1080038, 1080048,  
1080058

CONFORMEMENTE ALLA NORMA ED AL DOCUMENTO NORMATIVO ICIM  
IN COMPLIANCE WITH THE STANDARD AND WITH ICIM NORMATIVE DOCUMENT

**EN 1125:2008 - ICIM 0040CS**

CON CLASSIFICAZIONE EN 1125 :08 § 7.0 / WITH CLASSIFICATION EN1125 :08 § 7.0

3	7	7	A	1	4	2	2	A	A
---	---	---	---	---	---	---	---	---	---

CON CLASSIFICAZIONE ICIM 70R010 APP. E / WITH CLASSIFICATION ICIM 70R010 ANNEX E

3	500.000	300	A	1	4	2	2	A	A
---	---------	-----	---	---	---	---	---	---	---

**ICIM S.p.A.**

PRIMA EMISSIONE  
FIRST ISSUE

**15/12/2005**

EMISSIONE CORRENTE  
CURRENT ISSUE

**15/12/2017**

DATA DI SCADENZA  
EXPIRING DATE

**14/12/2020**

ICIM S.p.A. - Piazza Don Enrico Mapelli, 75 - 20099 Sesto San Giovanni (MI)



## Certificato di costanza delle prestazioni *Certificate of constancy of performance*

Certificato N. **0425 - CPR - 0997**  
Certificate No.

In conformità al Regolamento 305/2011/EU del Parlamento Europeo e del Consiglio del 9 marzo 2011 (Regolamento Prodotti da Costruzione o CPR), questo certificato si applica al prodotto da costruzione  
*In compliance with Regulation 305/2011/EU of the European Parliament and of the Council of 9 March 2011 (the Construction Products Certification or CPR), this certificate applies to the construction product*

ORGANISMO NOTIFICATO / NOTIFIED BODY

**ICIM S.p.A. - Identification number: 0425**  
Piazza Don Enrico Mapelli, 75 - 20099 Sesto San Giovanni (MI) - ITALY

DATI FABBRICANTE / MANUFACTURER DETAILS

### OMEC SERRATURE S.p.A.

SEDE LEGALE / HEAD OFFICE  
Via Caselli, 22  
25065 LUMEZZANE PIEVE (BS) - ITALY

UNITÀ OPERATIVA / PRODUCTION UNIT  
Via Caselli, 22  
25065 LUMEZZANE PIEVE (BS) - ITALY

DATI PRODOTTO / PRODUCT DETAILS

TIPOLOGIA / TYPE  
**Dispositivi antipanico per uscite di sicurezza azionati mediante una barra orizzontale / Panic exit devices**

SERIE / SERIES  
**6210**

Caratteristiche: vedi Allegato / Characteristics: see Annex

Questo certificato attesta che tutte le disposizioni riguardanti la valutazione e la verifica della costanza della prestazione e le prestazioni descritte nell'allegato ZA della norma EN 1125:2008 + EC1:2009 nell'ambito del sistema 1 sono applicati e che i prodotti soddisfano tutti i requisiti prescritti di cui sopra

*This certificate attests that all provisions concerning the assessment and verification of constancy of performance and the performances described in Annex ZA of the standard EN 1125:2008 + EC1:2009 under system 1 are applied and that the products fulfil all the prescribed requirements set out above.*

Questo certificato è stato emesso per la prima volta il 15/12/2005 e ha validità sino a che i metodi di prova e/o i requisiti del controllo della produzione in fabbrica stabiliti nella norma armonizzata, utilizzati per valutare la prestazione delle caratteristiche dichiarate, non cambino, e il prodotto e le condizioni di produzione nello stabilimento non subiscano modifiche significative.

*This certificate was first issued on 15/12/2005 and will remain valid as long as the test methods and/or factory production control requirements included in the harmonized standard, used to assess the performance of the declared characteristics, do not change, and the product, and the manufacturing conditions in the plant are not modified significantly.*

Il presente Certificato è da ritenersi valido solo se accompagnato dal relativo Allegato / This Certificate is valid only with the relative Annex

ICIM S.p.A.

EMISSIONE  
ISSUE

10/11/2015

ICIM S.p.A. a socio unico - Piazza Don Enrico Mapelli, 75 - 20099 Sesto San Giovanni (MI)

0070CERT\_00\_IT

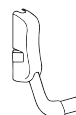

3	<p>CATEGORIA D'USO</p> <p>3 = uso molto frequente da parte di persone che possono non prestare attenzione, cioè possibilità di incidente o uso improprio</p>	<p>CATEGORY OF USE</p> <p>3 = high frequency of use where there is little incentive to exercise care; i.e. where there is a chance of an accident occurring and of misuse</p>
7	<p>DURABILITÀ</p> <p>6 = 100.000 cicli 7 = 200.000 cicli Classificazione ICIM = 500.000 cicli</p>	<p>DURABILITY</p> <p>6 = 100.000 test cycles 7 = 200.000 test cycles ICIM Classification = 500.000 test cycles</p>
7	<p>MASSA DELLA PORTA</p> <p>5 = fino a 100 Kg 6 = fino a 200 Kg 7 = oltre 200 Kg Classificazione ICIM = 300 Kg</p>	<p>DOOR MASS</p> <p>5 = up to 100 Kg 6 = up to 200 Kg 7 = over 200 Kg ICIM Classification = 300 Kg</p>
A	<p>IDONEITÀ ALL'USO SU PORTE TAGLIAFUOCO/ANTIFUMO</p> <p>0 = non adatto a porte tagliafuoco/antifumo A = adatto a porte antifumo B = adatto a porte tagliafuoco/antifumo</p>	<p>SUITABILITY FOR USE ON FIRE/SMOKE DOORS</p> <p>0 = not approved for use on fire/smoke doors A = suitable for use on smoke doors B = suitable for use on fire/smoke doors</p>
1	<p>SICUREZZA PER LE PERSONE</p> <p>1 = grado massimo per garantire la sicurezza delle persone</p>	<p>SAFETY</p> <p>1 = top grade: all panic exit devices have a critical safety function</p>
4	<p>RESISTENZA ALLA CORROSIONE</p> <p>3 = alta resistenza (96 h) 4 = altissima resistenza (240 h)</p>	<p>CORROSION RESISTANCE</p> <p>3 = high resistance (96 h) 4 = very high resistance (240 h)</p>
2	<p>SICUREZZA PER I BENI</p> <p>2 = la sicurezza dei beni risulta secondaria rispetto a quella delle persone</p>	<p>SECURITY</p> <p>2 = security requirements are secondary to those of safety</p>
2	<p>SPORGENZA DELLA BARRA</p> <p>1 = fino a 150 mm (maggiorata) 2 = fino a 100 mm (standard)</p>	<p>PROJECTION OF HORIZONTAL BAR</p> <p>1 = up to 150 mm (large) 2 = up to 100 mm (standard)</p>
A	<p>TIPO DI AZIONAMENTO</p> <p>A = barra a spinta B = barra a contatto</p>	<p>TYPE OF HORIZONTAL BAR OPERATION</p> <p>A = push bar B = touch bar</p>
A	<p>CAMPO DI APPLICAZIONE DELLA PORTA</p> <p>A = porta ad un'anta o porta a due ante: anta attiva o passiva B = solo porta ad un'anta C = porta a due ante, solo anta passiva</p>	<p>FIELD OF DOOR APPLICATION</p> <p>A = single door, double door: active or inactive B = single door only C = double door, inactive leaf only</p>



TRIPLICE (MODULARE) - THREE LOCKING POINTS (MODULAR)

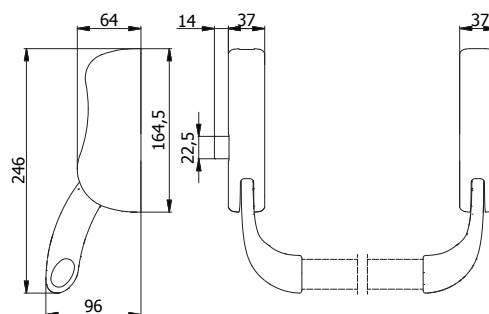

CARATTERISTICHE COSTRUTTIVE: Scatole in acciaio zincato - Coperchi in alluminio verniciato - Leve in lega speciale verniciata - Scrocco in lega speciale cromata - Molle in acciaio inox.

FUNZIONAMENTO: Scrocco comandato dalla barra orizzontale o dai comandi esterni.

PARTI IN DOTAZIONE: Contropiastra laterale, tappi in nylon, viti di fissaggio, istruzioni di montaggio, dime di foratura.

CONSTRUCTIVE FEATURES: Zinc-plated steel cases - Painted aluminium covers - Painted special alloy levers - Chromed special alloy latch bolt - Stainless steel springs.

WORKING: Horizontal bar or outside accessories driven latch bolt.

PROVIDED WITH: Side striker, nylon plugs, fixing screws, assembling instructions, templates for drilling.

COD.	Mano - Hand	Finitura - Finishing				
6213	Reversibile - Reversible	Nero - Black RAL 9005		2,18	1	10
6213/B	Reversibile - Reversible	Bianco - White RAL 9010		2,18	1	10
6213/B16	Reversibile - Reversible	Bianco - White RAL 9016		2,18	1	10
6213/G	Reversibile - Reversible	Grigio - Grey RAL 7040		2,18	1	10
6213/X	Reversibile - Reversible	Inox satinato Satinized stainless steel		2,18	1	10
6213 DX	Destro - Right	Nero - Black RAL 9005		1,95	1	10
6213/B DX	Destro - Right	Bianco - White RAL 9010		1,95	1	10
6213/B16 DX	Destro - Right	Bianco - White RAL 9016		1,95	1	10
6213/G DX	Destro - Right	Grigio - Grey RAL 7040		1,95	1	10
6213/X DX	Destro - Right	Inox satinato Satinized stainless steel		1,95	1	10
6213 SX	Sinistro - Left	Nero - Black RAL 9005		1,95	1	10
6213/B SX	Sinistro - Left	Bianco - White RAL 9010		1,95	1	10
6213/B16 SX	Sinistro - Left	Bianco - White RAL 9016		1,95	1	10
6213/G SX	Sinistro - Left	Grigio - Grey RAL 7040		1,95	1	10
6213/X SX	Sinistro - Left	Inox satinato Satinized stainless steel		1,95	1	10

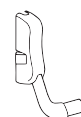

BARRE ORIZZONTALI - HORIZONTAL BARS

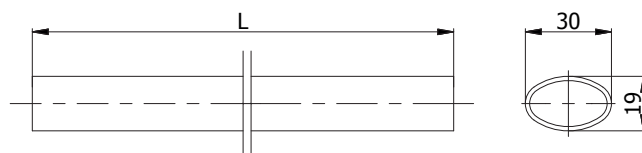
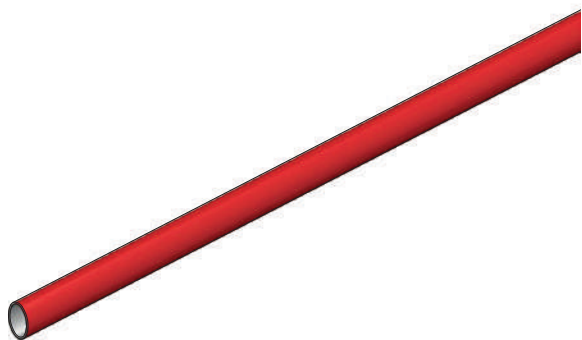

MATERIALE: Acciaio verniciato.  
PARTI IN DOTAZIONE: Tappi in nylon.

MATERIAL: Painted steel.  
PROVIDED WITH: Nylon plugs.

COD.	L	Finitura - Finishing					
6005 AB	1130	Bianco - White	RAL 9010		1,06	10	-
6005 AB16	1130	Bianco - White	RAL 9016		1,06	10	-
6005 AG	1130	Grigio - Grey	RAL 7040		1,06	10	-
6005 AN	1130	Nero - Black	RAL 9005		1,06	10	-
6005 AR	1130	Rosso - Red	RAL 3020		1,06	10	-
6005 AV	1130	Verde - Green	RAL 6024		1,06	10	-
6006 AB	1480	Bianco - White	RAL 9010		1,32	10	-
6006 AB16	1480	Bianco - White	RAL 9016		1,32	10	-
6006 AG	1480	Grigio - Grey	RAL 7040		1,32	10	-
6006 AN	1480	Nero - Black	RAL 9005		1,32	10	-
6006 AR	1480	Rosso - Red	RAL 3020		1,32	10	-
6006 AV	1480	Verde - Green	RAL 6024		1,32	10	-

MATERIALE: Acciaio inox.  
PARTI IN DOTAZIONE: Tappi in nylon.

MATERIAL: Stainless steel.  
PROVIDED WITH: Nylon plugs.

COD.	L	Finitura - Finishing					
6005 X	1130	Satinato - Satinized			1,20	10	-
6006 X	1330	Satinato - Satinized			1,50	10	-

KIT DEVIATORI ALTO/BASSO - TOP AND BOTTOM BOLTS KIT

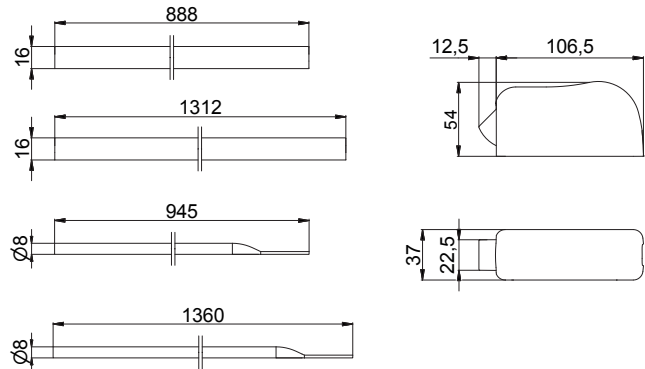

**CARATTERISTICHE COSTRUTTIVE:** Scatole in acciaio zincato - Coperchi in alluminio verniciato - Scrocchi in lega speciale cromata - Molle in acciaio inox - Aste in acciaio zincato - Copriasta in alluminio verniciato.

**APPLICAZIONE:** Maniglioni antipanico triplici.

**PARTI IN DOTAZIONE:** Contropiastra laterale, contropiastra a pavimento, viti e accessori di fissaggio.

**CONSTRUCTIVE FEATURES:** Zinc-plated steel cases - Painted aluminium covers - Chromed special alloy latch bolts - Stainless steel springs - Zinc-plated steel rods - Painted aluminium cover rod.

**APPLICATION:** Three locking points panic exit devices.

**PROVIDED WITH:** Side striker, floor striker, fixing screws and fixing accessories.

COD.	Finitura - Finishing				
6040	Nero - Black	RAL 9005		2,22	1 -
6040/B	Bianco - White	RAL 9010		2,22	1 -
6040/B16	Bianco - White	RAL 9016		2,22	1 -
6040/G	Grigio - Grey	RAL 7040		2,22	1 -
6040/X	Inox satinato Satinized stainless steel			2,22	1 -

KIT DEVIATORI LATERALI - SIDE LATCHES KIT

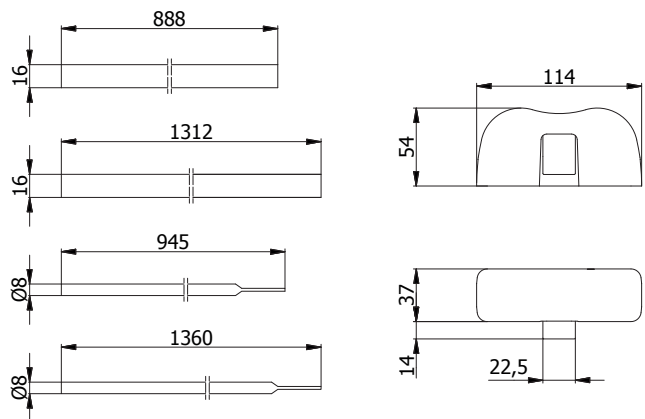

**CARATTERISTICHE COSTRUTTIVE:** Scatole in acciaio zincato - Coperchi in alluminio verniciato - Scrocchi in lega speciale cromata - Molle in acciaio inox - Aste in acciaio zincato - Copriasta in alluminio verniciato.

**APPLICAZIONE:** Maniglioni antipanico triplici.

**PARTI IN DOTAZIONE:** 2 contropiastre laterali, viti e accessori di fissaggio.

**CONSTRUCTIVE FEATURES:** Zinc-plated steel cases - Painted aluminium covers - Chromed special alloy latch bolts - Stainless steel springs - Zinc-plated steel rods - Painted aluminium cover rod.

**APPLICATION:** Three locking points panic exit devices.

**PROVIDED WITH:** 2 side strikers, fixing screws and fixing accessories.

COD.	Finitura - Finishing				
6041	Nero - Black	RAL 9005		2,21	1 -
6041/B	Bianco - White	RAL 9010		2,21	1 -
6041/B16	Bianco - White	RAL 9016		2,21	1 -
6041/G	Grigio - Grey	RAL 7040		2,21	1 -
6041/X	Inox satinato Satinized stainless steel			2,21	1 -



PLACCA ESTERNA CON MANIGLIA E CILINDRO  
OUTSIDE PLATE WITH HANDLE AND CYLINDER

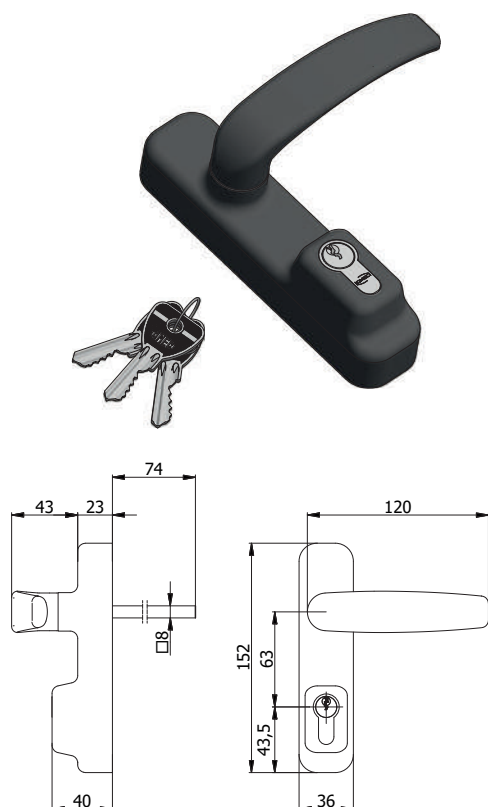

**CARATTERISTICHE COSTRUTTIVE:** Scatola e maniglia in lega speciale verniciata - Coperchio in acciaio zincato e plastificato - Cilindro in ottone nichelato.

**FUNZIONAMENTO:** Apertura porta comandata dalla maniglia - Blocco maniglia comandato dalla chiave (maniglia fissa).

**PARTI IN DOTAZIONE:** 3 chiavi, viti di fissaggio, istruzioni di montaggio, dima di foratura.

**CONSTRUCTIVE FEATURES:** Painted special alloy case and handle - Zinc and plastic plated steel cover - Nickel-plated brass cylinder.

**WORKING:** Door opened by the handle - Handle interlock is controlled by the key (blocked handle).

**PROVIDED WITH:** 3 keys, fixing screws, assembling instructions, template for drilling.

COD.			Finitura - Finishing			
6011	121/04 H	105/05	Nero - Black RAL 9005		1,00	1 -
6011/B	121/04 H	105/05	Bianco - White RAL 9010		1,00	1 -
6011/B16	121/04 H	105/05	Bianco - White RAL 9016		1,00	1 -
6011/G	121/04 H	105/05	Grigio - Grey RAL 7040		1,00	1 -
6011/X	121/04 H	105/05	Inox satinato Satinized stainless steel		1,00	1 -

PLACCA ESTERNA CON MANIGLIA LIBERA E CILINDRO  
OUTSIDE PLATE WITH FREE HANDLE AND CYLINDER

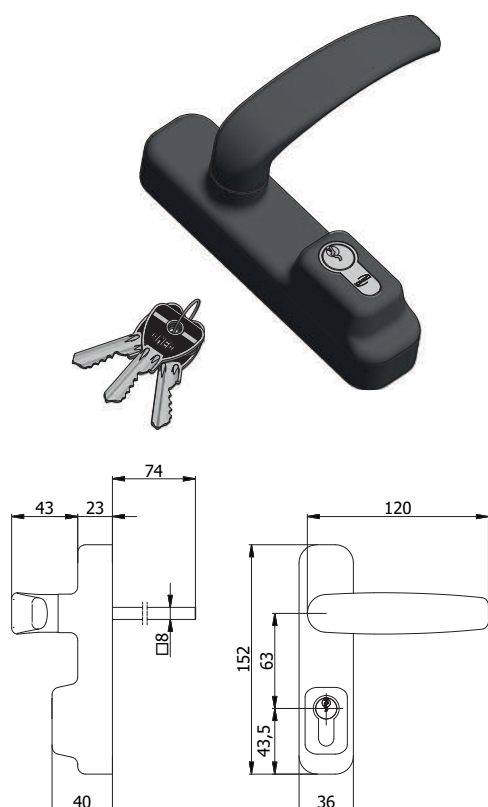

**CARATTERISTICHE COSTRUTTIVE:** Scatola e maniglia in lega speciale verniciata - Coperchio in acciaio zincato e plastificato - Cilindro in ottone nichelato.

**FUNZIONAMENTO:** Apertura porta comandata dalla maniglia - Blocco maniglia comandato dalla chiave (maniglia frizionata).

**PARTI IN DOTAZIONE:** 3 chiavi, viti di fissaggio, istruzioni di montaggio, dima di foratura.

**CONSTRUCTIVE FEATURES:** Painted special alloy case and handle - Zinc and plastic plated steel cover - Nickel-plated brass cylinder.

**WORKING:** Door opened by the handle - Handle interlock is controlled by the key (free handle).

**PROVIDED WITH:** 3 keys, fixing screws, assembling instructions, template for drilling.

COD.			Finitura - Finishing			
6012	121/04 H	105/05	Nero - Black RAL 9005		0,99	1 -
6012/B	121/04 H	105/05	Bianco - White RAL 9010		0,99	1 -
6012/B16	121/04 H	105/05	Bianco - White RAL 9016		0,99	1 -
6012/G	121/04 H	105/05	Grigio - Grey RAL 7040		0,99	1 -
6012/X	121/04 H	105/05	Inox satinato Satinized stainless steel		0,99	1 -



PLACCA ESTERNA CON MANIGLIA E CILINDRO A CHIAVE PIATTA  
OUTSIDE PLATE WITH HANDLE AND FLAT KEY CYLINDER



**CARATTERISTICHE COSTRUTTIVE:** Scatola e maniglia in lega speciale verniciata - Coperchio in acciaio zincato e plastificato - Cilindro in ottone nichelato.

**FUNZIONAMENTO:** Apertura porta comandata dalla maniglia - Blocco maniglia comandato dalla chiave (maniglia fissa).

**PARTI IN DOTAZIONE:** 3 chiavi, viti di fissaggio, istruzioni di montaggio, dima di foratura.

**CONSTRUCTIVE FEATURES:** Painted special alloy case and handle - Zinc and plastic plated steel cover - Nickel-plated brass cylinder.

**WORKING:** Door opened by the handle - Handle interlock is controlled by the key (blocked handle).

**PROVIDED WITH:** 3 keys, fixing screws, assembling instructions, template for drilling.

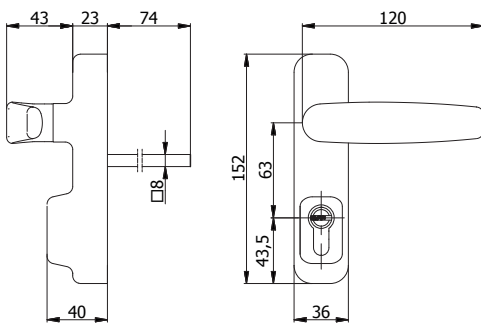

COD.			Finitura - Finishing			
6013	2121/04 H	2020/06	Nero - Black RAL 9005	1,02	1	-
6013/B	2121/04 H	2020/06	Bianco - White RAL 9010	1,02	1	-
6013/B16	2121/04 H	2020/06	Bianco - White RAL 9016	1,02	1	-
6013/G	2121/04 H	2020/06	Grigio - Grey RAL 7040	1,02	1	-
6013/X	2121/04 H	2020/06	Inox satinato Satinized stainless steel	1,02	1	-

PLACCA ESTERNA CON MANIGLIA LIBERA E CILINDRO A CHIAVE PIATTA  
OUTSIDE PLATE WITH FREE HANDLE AND FLAT KEY CYLINDER



**CARATTERISTICHE COSTRUTTIVE:** Scatola e maniglia in lega speciale verniciata - Coperchio in acciaio zincato e plastificato - Cilindro in ottone nichelato.

**FUNZIONAMENTO:** Apertura porta comandata dalla maniglia - Blocco maniglia comandato dalla chiave (maniglia frizionata).

**PARTI IN DOTAZIONE:** 3 chiavi, viti di fissaggio, istruzioni di montaggio, dima di foratura.

**CONSTRUCTIVE FEATURES:** Painted special alloy case and handle - Zinc and plastic plated steel cover - Nickel-plated brass cylinder.

**WORKING:** Door opened by the handle - Handle interlock is controlled by the key (free handle).

**PROVIDED WITH:** 3 keys, fixing screws, assembling instructions, template for drilling.

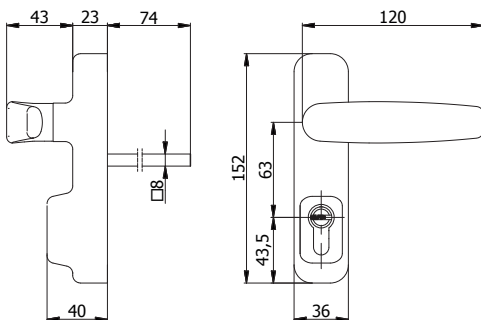

COD.			Finitura - Finishing			
6014	2121/04 H	2020/06	Nero - Black RAL 9005	1,01	1	-
6014/B	2121/04 H	2020/06	Bianco - White RAL 9010	1,01	1	-
6014/B16	2121/04 H	2020/06	Bianco - White RAL 9016	1,01	1	-
6014/G	2121/04 H	2020/06	Grigio - Grey RAL 7040	1,01	1	-
6014/X	2121/04 H	2020/06	Inox satinato Satinized stainless steel	1,01	1	-



MEZZO CILINDRO NICHELATO - NICKEL-PLATED HALF CYLINDER

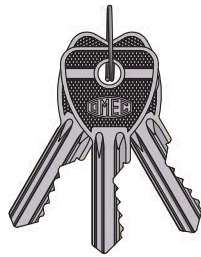
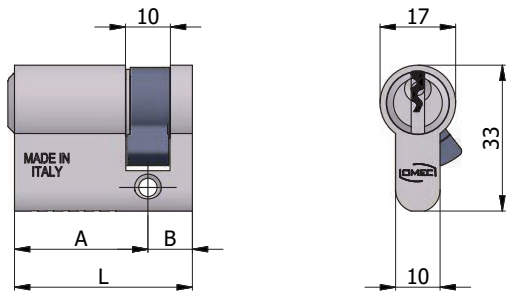

**CARATTERISTICHE COSTRUTTIVE:** Corpo in ottone nichel satinato - Barilotto in ottone nichelato con guida chiave- Perni e controperni in acciaio inox - Molle in bronzo fosforoso - Camma DIN disassata di 30° in acciaio autolubrificante - Chiavi in ottone nichelato.

**FUNZIONAMENTO:** Rotazione della chiave di 360°.

**PARTI IN DOTAZIONE:** 3 chiavi.

**VARIANTI A RICHIESTA:** Impianti speciali KA-MK-GMK-CL.

**CONSTRUCTIVE FEATURES:** Satin nickel-plated brass body - Easy entrance key nickel-plated brass plug - Stainless steel pins and drivers - Phosphor bronze springs - Steel off center 30° DIN cam - Nickel-plated brass keys.

**WORKING:** Turn the key 360°.

**PROVIDED WITH:** 3 keys.

**ON REQUEST:** Special keying systems KA-MK-GMK-CL.

COD.	L	A	B			Spessore porta Door thickness			
121/04 H*	40	30	10	5	105/05	-	0,14	1	10
121/12 H	97	87	10	5	105/05	60 ÷ 75	0,29	1	5
121/13 H	107	97	10	5	105/05	76 ÷ 85	0,31	1	5
121/24 H	70	60	10	5	105/05	40 ÷ 49	0,22	1	10
121/26 H	80	70	10	5	105/05	50 ÷ 59	0,24	1	10

\*Per placche esterne cod.6011-6012

\*For outside plates cod.6011-6012

MEZZO CILINDRO NICHELATO CHIAVE PIATTA - NICKEL-PLATED HALF FLAT KEY CYLINDER

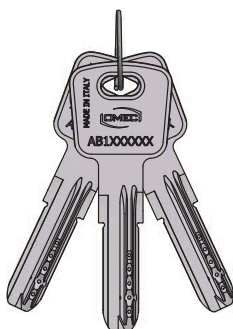
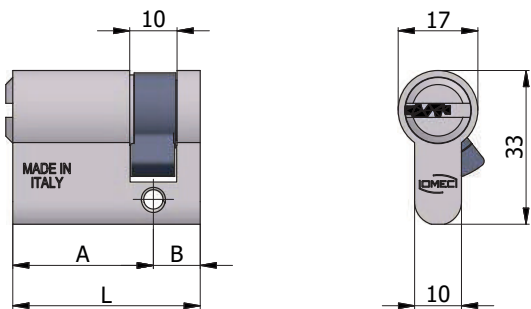

**CARATTERISTICHE COSTRUTTIVE:** Corpo in ottone nichel satinato - Barilotto in ottone nichelato con guida-chiave - Perni e controperni in acciaio inox - Molle in bronzo fosforoso - Camma DIN disassata di 30° in acciaio autolubrificante - Chiavi piatte reversibili in alpacca con numero di codice.

**FUNZIONAMENTO:** Rotazione della chiave di 360°.

**PARTI IN DOTAZIONE:** 3 chiavi.

**VARIANTI A RICHIESTA:** Impianti speciali KA-MK-GMK-CL.

**CONSTRUCTIVE FEATURES:** Satin nickel-plated brass body - Easy entrance key nickel-plated brass plug - Stainless steel pins and drivers - Phosphor bronze springs - Steel off center 30° DIN cam - Silver-nickel reversible flat keys with code number.

**WORKING:** Turn the key 360°.

**PROVIDED WITH:** 3 keys.

**ON REQUEST:** Special keying systems KA-MK-GMK-CL.

COD.	L	A	B			Spessore porta Door thickness			
2121/04 H*	40	30	10	6	2020/06	-	0,15	1	10
2121/24 H	70	60	10	6	2020/06	40 ÷ 49	0,26	1	10
2121/26 H	80	70	10	6	2020/06	50 ÷ 59	0,29	1	10
2121/27 H	90	80	10	6	2020/06	60 ÷ 69	0,33	1	5

\*Per placche esterne cod.6013-6014

\*For outside plates cod.6013-6014

ASTA LUNGA PER DEVIATORI  
LONG ROD FOR LOCKING KIT

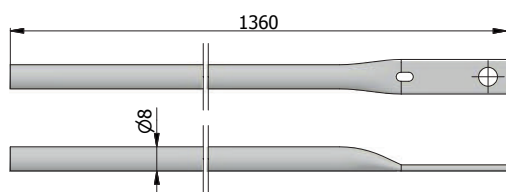

COD.	Materiale - Material	kg		
AST006	Acciaio zincato - Zinc-plated steel	0,231	10	-

CONTROPIASTRA LATERALE  
SIDE STRIKER

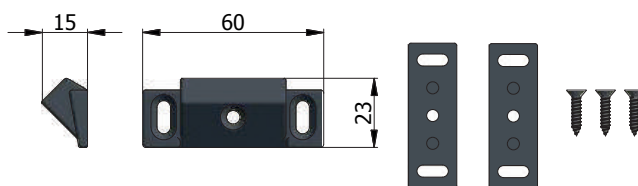

COD.	Materiale - Material	kg		
ANY117	Lega speciale verniciata nera Black painted special alloy	0,085	10	-
ANY118	Lega speciale cromata Chromed special alloy	0,085	10	-

COPRIASTA LUNGO  
LONG COVER ROD

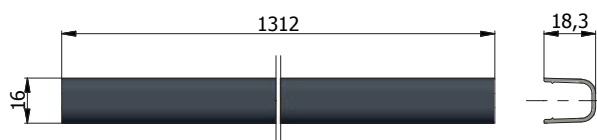

COD.	Materiale - Material	kg		
AST016	Alluminio nero - Black aluminium	RAL 9005	0,224	10 -
AST022	Alluminio bianco - White aluminium	RAL 9010	0,224	10 -
AST025	Alluminio grigio - Grey aluminium	RAL 7040	0,224	10 -
AST052	Alluminio satinato - Satinized aluminium	-	0,224	10 -
AST055	Alluminio bianco - White aluminium	RAL 9016	0,224	10 -

CONTROPIASTRA A PAVIMENTO  
FLOOR STRIKER

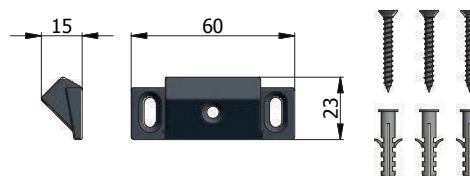

COD.	Materiale - Material	kg		
ANY119	Lega speciale verniciata nera Black painted special alloy	0,055	10	-
ANY120	Lega speciale cromata Chromed special alloy	0,055	10	-

KIT DI PROLUNGA PER DEVIATORI  
PROLONGATION KIT FOR DEVIATORS

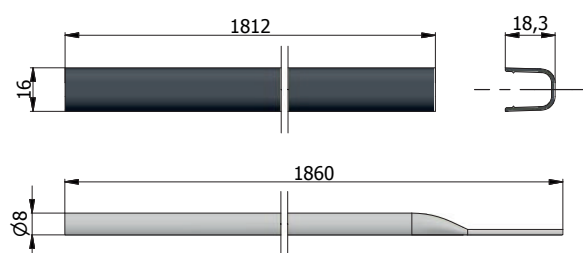

Per porte fino a 3000 mm di altezza  
For doors high up to 3000 mm

COD.	Finitura - Finishing	kg		
6032	Nero - Black	RAL 9005	0,650	5 -
6032/B	Bianco - White	RAL 9010	0,650	5 -
6032/B16	Bianco - White	RAL 9016	0,650	5 -
6032/G	Grigio - Grey	RAL 7040	0,650	5 -
6032/X	Inox satinato - Satinized stainless steel	-	0,650	5 -

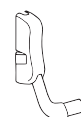

UN PUNTO DI CHIUSURA - ONE LOCKING POINT

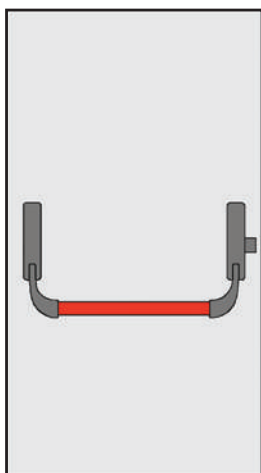

6213  
6213 DX

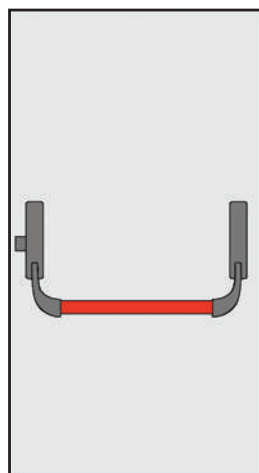

6213  
6213 SX

DUE PUNTI DI CHIUSURA - TWO LOCKING POINTS

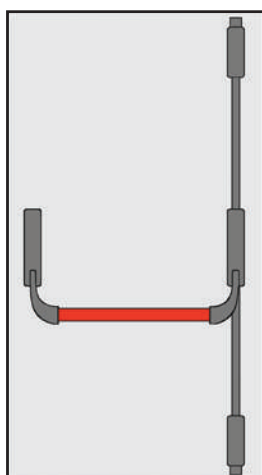

6213 + 6040  
6213 DX + 6040

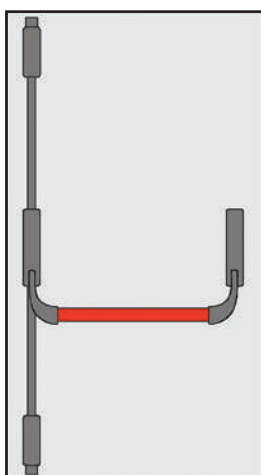

6213 + 6040  
6213 SX + 6040

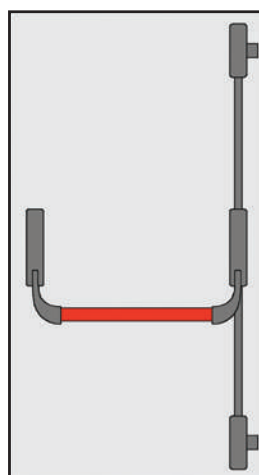

6213 + 6041  
6213 DX + 6041

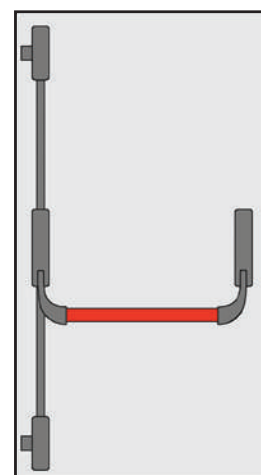

6213 + 6041  
6213 SX + 6041

TRE PUNTI DI CHIUSURA - THREE LOCKING POINTS

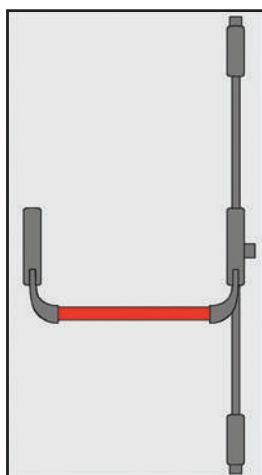

6213 + 6040  
6213 DX + 6040

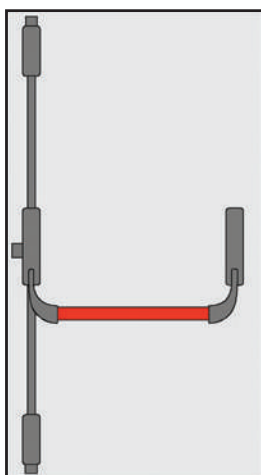

6213 + 6040  
6213 SX + 6040

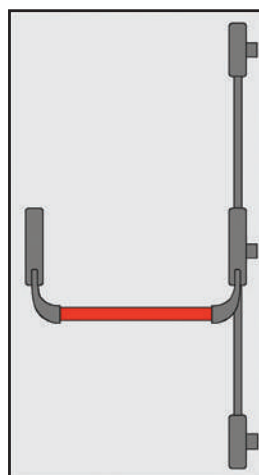

6213 + 6041  
6213 DX + 6041

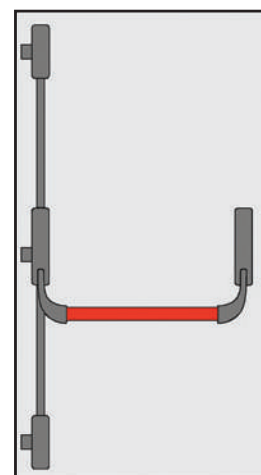

6213 + 6041  
6213 SX + 6041

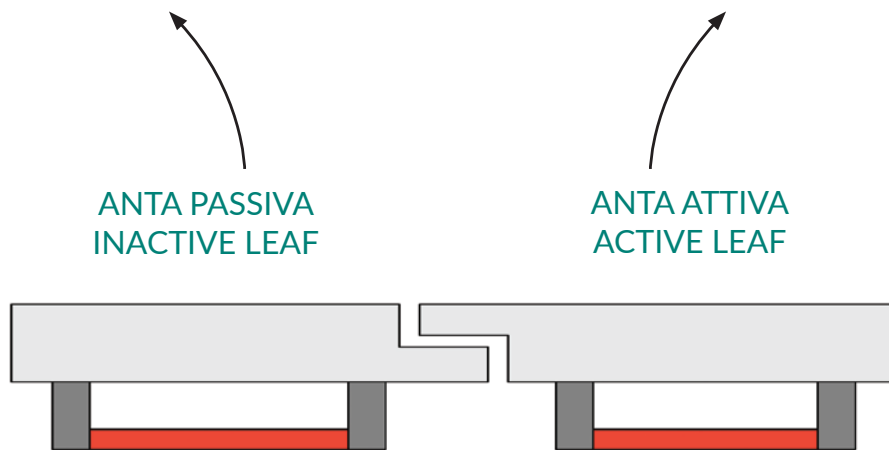

TRE PUNTI DI CHIUSURA - THREE LOCKING POINTS

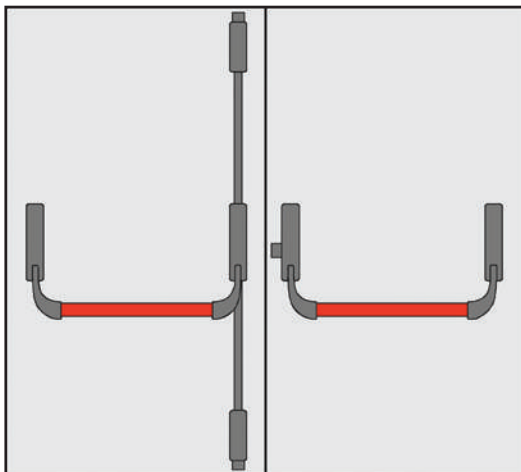

6213 + 6040  
6213 DX + 6040

6213  
6213 SX

QUATTRO PUNTI DI CHIUSURA - FOUR LOCKING POINTS

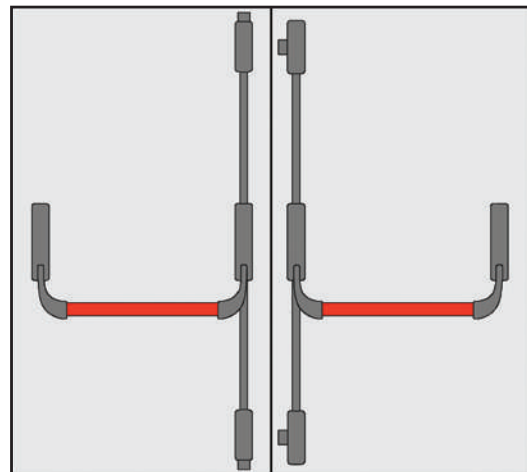

6213 + 6040  
6213 DX + 6040

6213 + 6041  
6213 SX + 6041

CINQUE PUNTI DI CHIUSURA - FIVE LOCKING POINTS

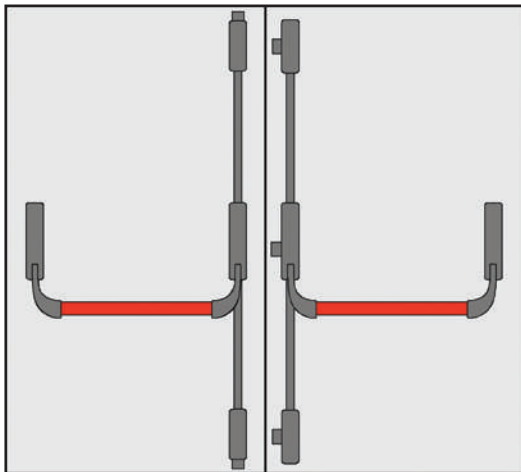

6213 + 6040  
6213 DX + 6040

6213 + 6041  
6213 SX + 6041

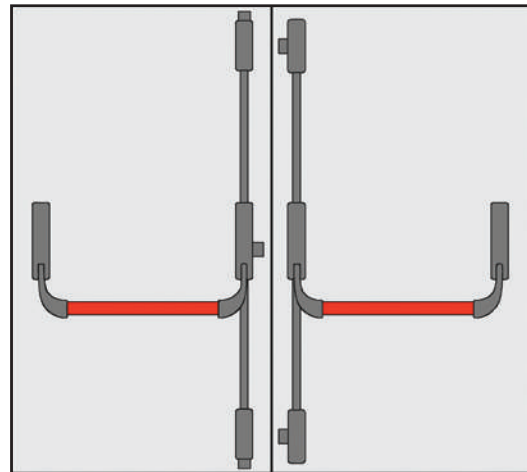

6213 + 6040  
6213 DX + 6040

6213 + 6041  
6213 SX + 6041





