

LS400

STAC ELEVABLE

Lift & Slide

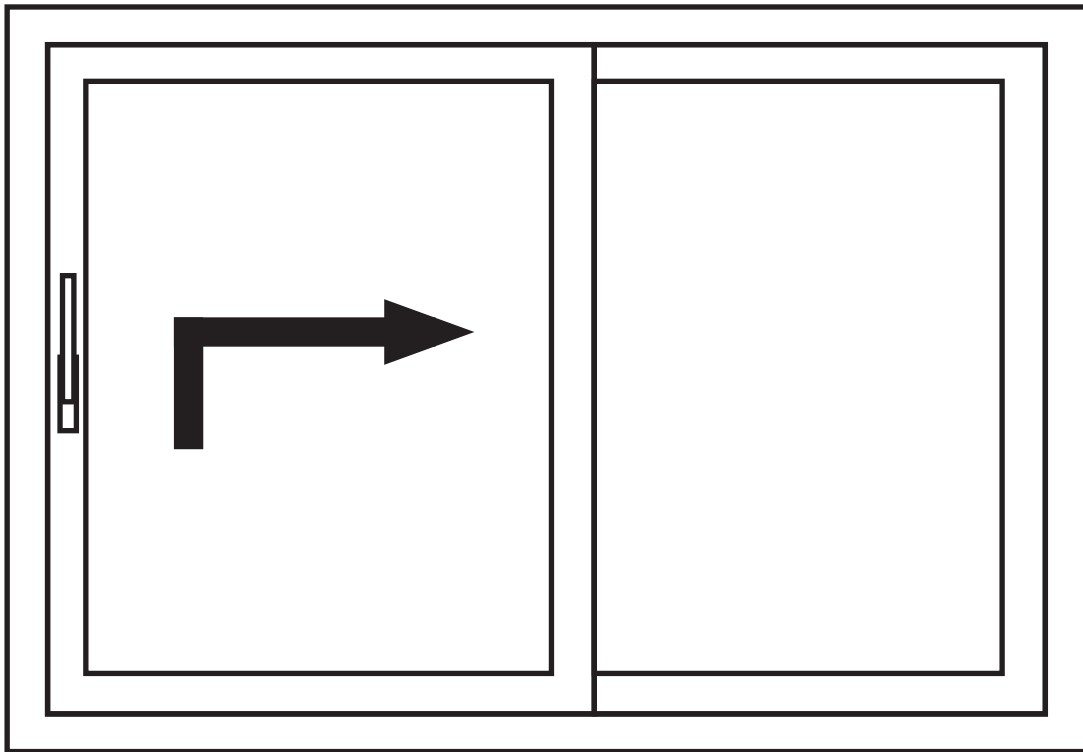

Sistema de herraje para corredera elevable LS400
Hardware system for Lift and Slide LS400

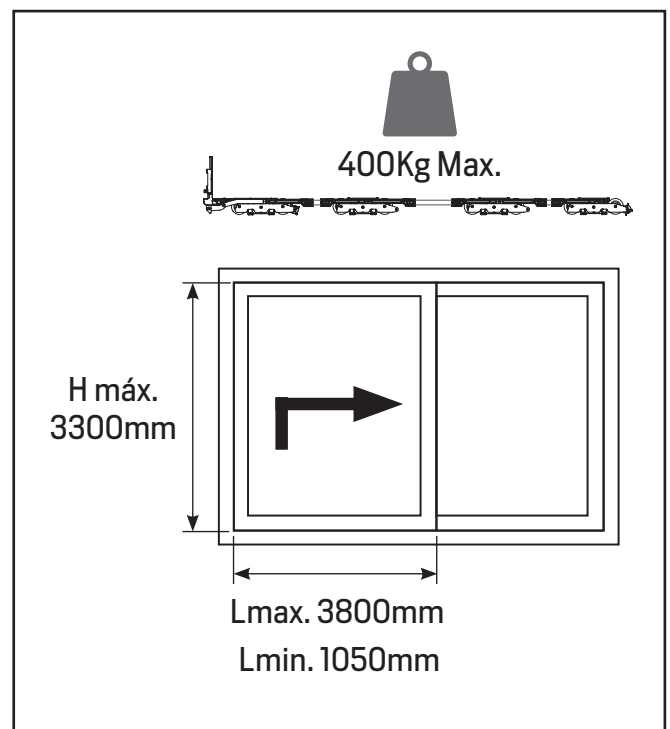
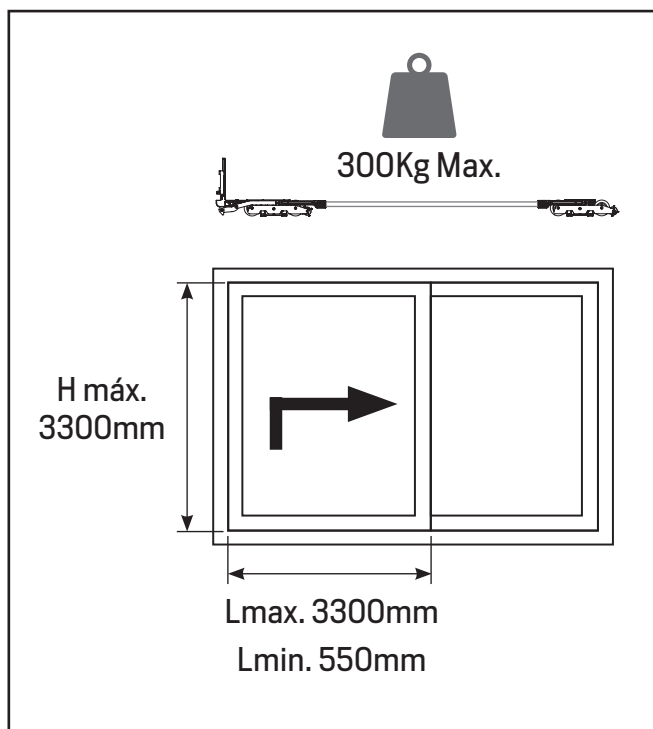

PARA CONFIGURACIONES DE GRANDES DIMENSIONES Y PESOS CONSULTAR CON EL DEPARTAMENTO TÉCNICO DE STAC (ofitecna2@stac.es).
IN CASE OF HEAVY WEIGHT AND LARGE DIMENSIONS, PLEASE CONTACT TO STAC TECHNICAL DEPARTMENT (ofitecna2@stac.es).

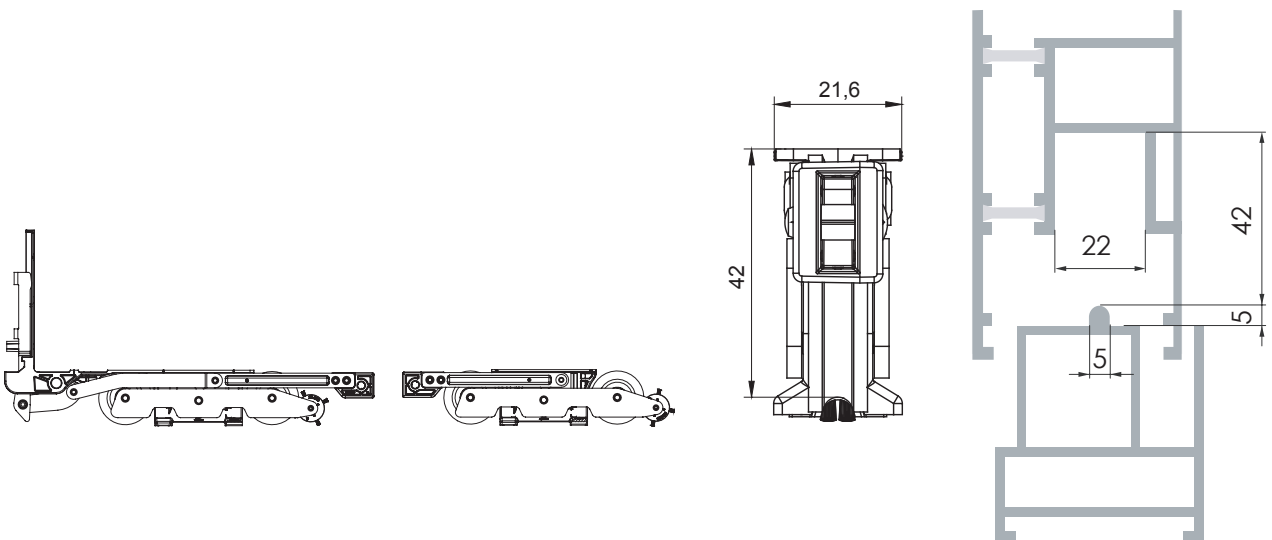
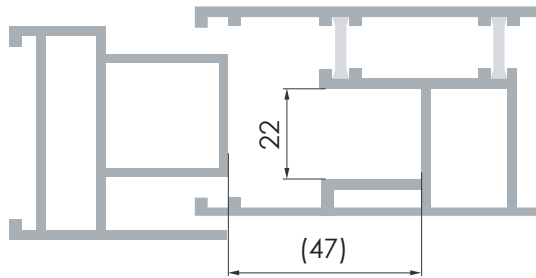
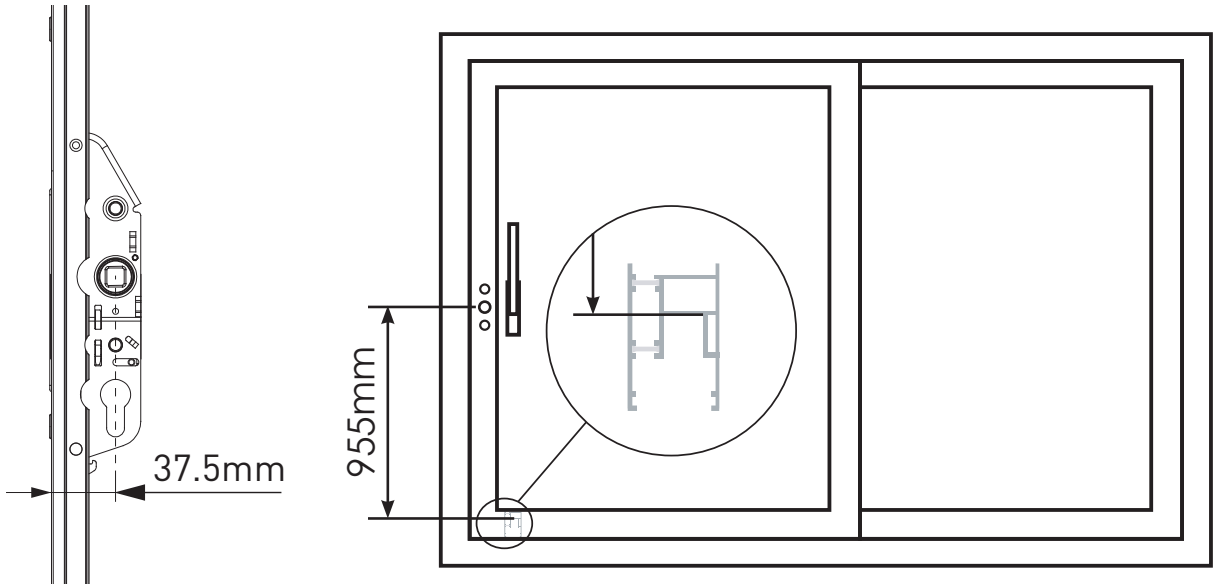

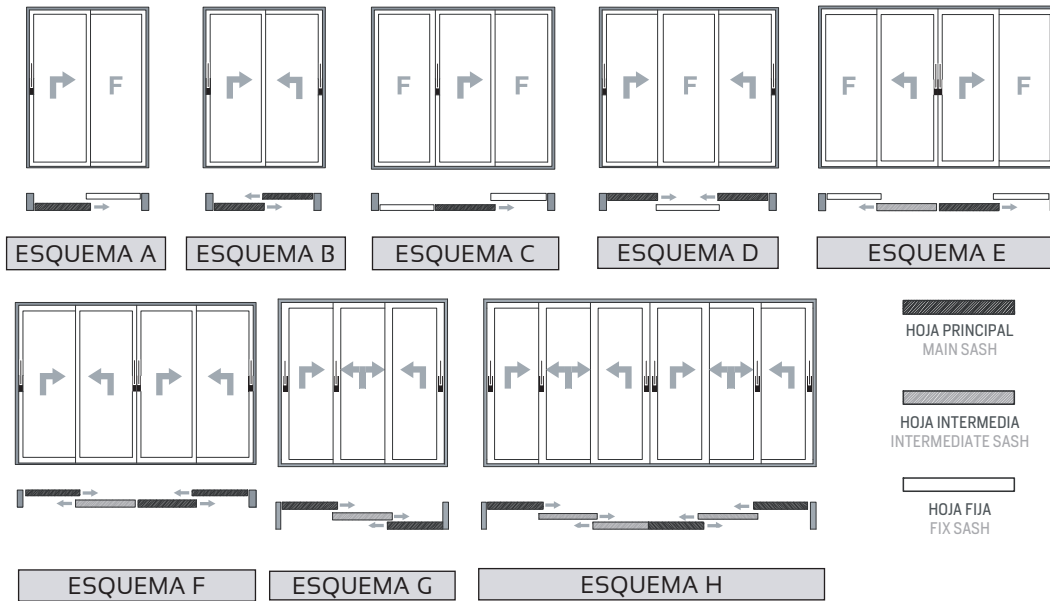



REF.	DESCRIPCIÓN / DESCRIPTION	VER ESQUEMA DE APLICACIÓN / SEE APPLICATION DRAWING								
		A	B	C	D	E	F	G	H	
		Uds	Uds	Uds	Uds	Uds	Uds	Uds	Uds	
Ver Tabla manillas (pag. 6) See table page 6	MANILLA DOBLE MANILLA MANILLA-UNERO HANDLE DOUBLE HANDLE HANDLE - FINGER GRIP	1	2	1	2	2	4	3	6	
233001	CARRO DELANTERO / FRONT BOGIE	1	2	1	2	2	4	3	6	
233002	CARRO TRASERO / REAR BOGIE	1	2	1	2	2	4	3	6	
233004	CARRO FIJO / FIXED LEAD SUPPORT	2	-	4	2	4	-	-	-	
233010	PLETINA UNION DE CARROS CONNECTING ROD	2760 mm	1	2	1	2	2	4	3	6
233011		1760 mm								
233012		1260 mm								
233013		756 mm								
234001	FRENTE FALLEBA DRIVE GEAR	1800mm - 2100mm	1	2	1	2	1+1*	3+1*	2+1*	3+3*
234002		2101mm - 2400mm								
234003		2401mm - 2700mm								
234101	KIT DE CERRADEROS / LOCKING POINTS KIT		1	2	1	2	1	3	2	3
234102	KIT DE CERRADEROS (CALZO 15mm) / LOCKING POINTS KIT (15mm WEDGE)		1	2	1	2	1	3	2	3
234103	KIT DE ACCESORIOS HOJA INTERMEDIA ACCESSORIES KIT FOR INTERMEDIATE SASH		-	-	-	-	1	1	1	3
234022	CERRADERO HORIZONTAL / FRAME LOCK POINT		-	-	-	-	1	1	1	3
234025	TOPE FIN DE CARRERA - BLANCO / STOPPER WHITE		(1)	(1)	(1)	(2)	(2)	(2)	(2)	(4)
234026	TOPE FIN DE CARRERA - NEGRO / STOPPER BLACK		(1)	(1)	(1)	(2)	(2)	(2)	(2)	(4)
235201	KIT DE CALZOS FRONTAL FRONTAL WEDGES KIT	14 mm	1	2	1	2	2	4	3	6
235202		17 mm								
235203		15.5 mm								
235204		18 mm								
Para hojas de mas de 300Kg / For more than 300Kg per sash										
233003	CARRO INTERMEDIO / INTERMEDIATE BOGIE		2 por cada hoja elevable / 2 per lift sash							
233004	CARRO FIJO / FIXED LEAD SUPPORT		+2 por cada hoja fija / +2 per fixed sash							

(*) Opcional / Optional

* Para las hojas intermedias siempre se puede instalar la falleba mas corta 234001 / For intermediate sash is always possible to install the shortest drive gear 234001

Disponibles Kits de tornillería. Consultar disponibilidad por serie. / Screws kits are available. Consult availability per serie.

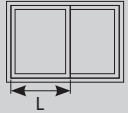
SELECCIÓN DE PLETINAS CONECTORAS DE CARROS
CONNECTING ROD SETTING

		300Kg Max.				400Kg Max.			
									
L = (mm)		550 - 1300	1301 - 1800	1801 - 2300	2301 - 3300	1050 - 1800	1801 - 2300	2301 - 2800	2801 - 3800
REF.	Longitud pletina Connecting Rod lenght								
233013	756 mm	1	-	-	-	1	-	-	-
233012	1260 mm	-	1	-	-	-	1	-	-
233011	1760 mm	-	-	1	-	-	-	1	-
233010	2760 mm	-	-	-	1	-	-	-	1

SELECCIÓN DE FRENTE FALLEBA
DRIVE GEAR SETTING

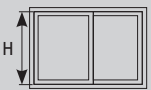
		CON 3 - 4 PUNTOS DE CIERRE				CON 4-5 PUNTOS DE CIERRE	
							
H = (mm)		1800 - 2200	2201 - 2500	2501 - 2800	2801 - 3300	2801 - 3300	
REF.	DENOMINACIÓN						
234001	FRENTE FALLEBA 2100mm / DRIVE GEAR 2100mm	1	-	-	-	-	
234002	FRENTE FALLEBA 2400mm / DRIVE GEAR 2400mm	-	1	-	-	-	
234003	FRENTE FALLEBA 2700mm / DRIVE GEAR 2700mm	-	-	1	1	1	
234010	EMBELLECEDOR 500mm / DRIVE COVER 2100mm	-	-	-	1	-	
234011	CONJUNTO ALARGADOR 500mm GEAR EXTENSION 500mm	-	-	-	-	1	
234020	CERRADERO* LOCKING POINT*	SIN CALZO / WITHOUT WEDGE	0-1	0-1	0-1	0-1	1-2
234023		CON CALZO / WITH WEDGE					
235001	CALZOS FALLEBA DRIVE GEAR WEDGES	14 mm	-	-	-	-	2
235002		17 mm					
235003		15.5 mm					
235004		18 mm					

*Los kits 234101 - 234102 - 234103 incluyen 3 puntos de cierre, para añadir un punto de cierre adicional se pedirá una de las referencias de la tabla.

*The kits 234101 - 234102 - 234103 include 3 locking points, to include another one, will be required one of the references in table.

La falleba incluye 3 puntos de cierre abiertos con la posibilidad de abrir un punto de cierre adicional. (mas informacion en la pagina 13)

The drive gear allows 3 locking points, with the possibility of enable one more. (more information in page 13)

Componentes del sistema de corredera elevable:

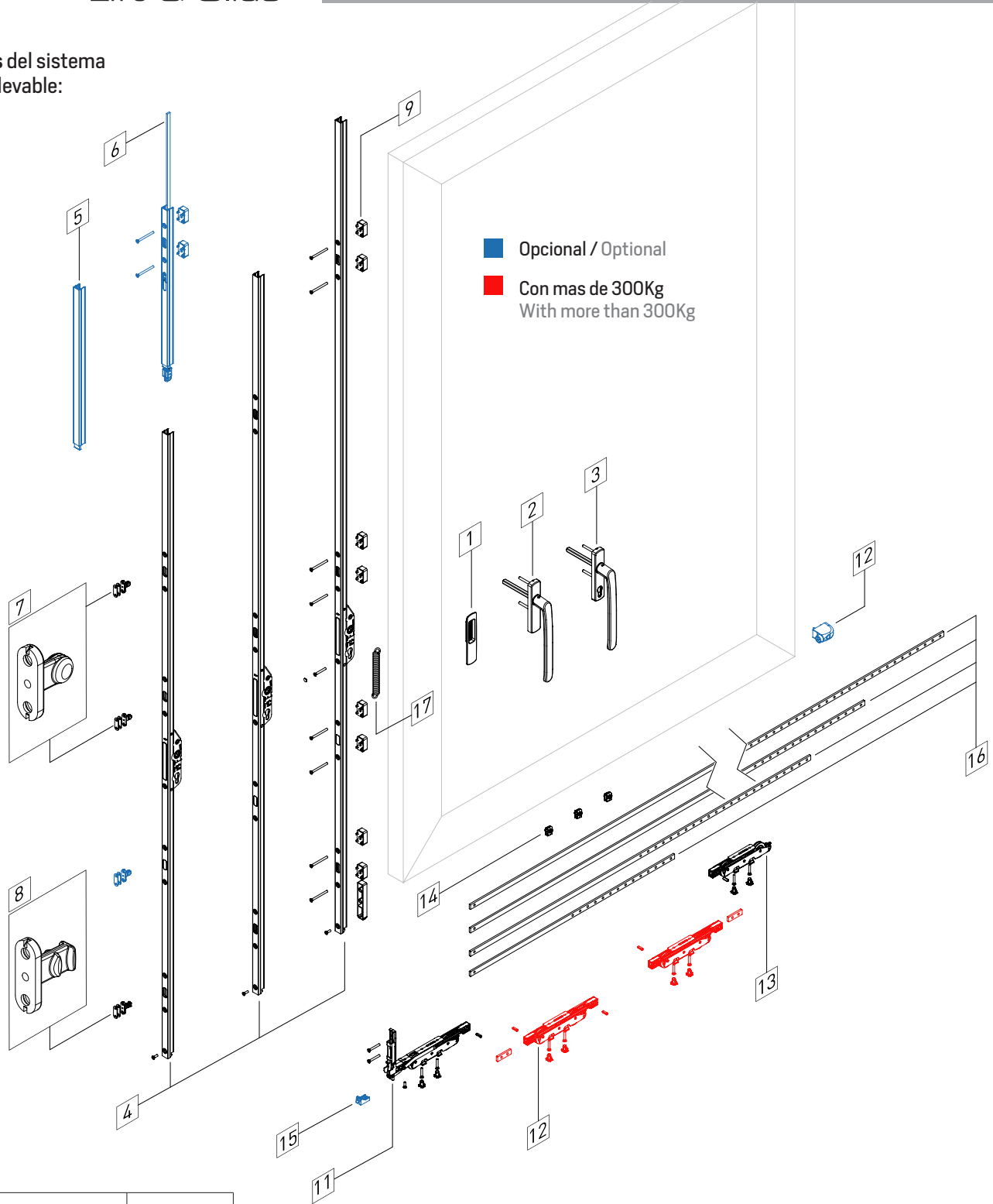







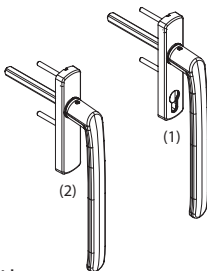

■ Opcional / Optional
■ Con mas de 300Kg
With more than 300Kg

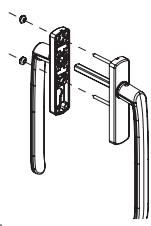
1	Uñero Finger grip	Pag. 6
2	Manillón sin bocallave Handle	
3	Manillón con bocallave Handle with lock	
4	Frente Falleba 2100 mm 2100 mm drive gear	234001
	Frente Falleba 2400 mm 2400 mm drive gear	234002
	Frente Falleba 2700 mm 2700 mm drive gear	234003
5	Embellecedor Drive cover	234010
6	Conjunto alargador 500 mm Gear extension	234011

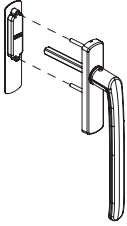
7	Punto de cierre Locking point	234021
8	Microventilación Micro-ventilation	234022
9	Calzos Falleba Drive gear wedges	Pag. 7
10	Pletina carros 2760 mm 2760 mm connecting rod	233010
	Pletina carros 1760 mm 1760 mm connecting rod	233011
	Pletina carros 1260 mm 1260 mm connecting rod	233012
	Pletina carros 756 mm 756 mm connecting rod	233013

11	Carro principal Front bogie	233001
12	Carro trasero Rear bogie	233002
13	Carros intermedios Intermediate bogies	233003
14	Calzo Pletina Connecting Rod wedge	0423071
15	Punto de cierre horizontal Frame lock point	234022
16	Tope fin de carrera Stopper	Pag. 9
17	Resorte Falleba Drive gear spring	23037

MANILLON ATRIA ATRIA HANDLE		
 236001 Incluido 236001 Included	(1) MANILLON ATRIA CON BOCALLAVE (1) ATRIA HANDLE WITH KEYHOLE	2301**  2311**
	(2) MANILLON ATRIA SIN BOCALLAVE (2) ATRIA HANDLE WITHOUT KEYHOLE	2302**  2312**
 236002 Incluido 236002 Included	JUEGO MANILLON ATRIA CON BOCALLAVE ATRIA DOUBLE HANDLE WITH KEYHOLE	2303**  2313**
	JUEGO MANILLON ATRIA SIN BOCALLAVE ATRIA DOUBLE HANDLE WITHOUT KEYHOLE	2304**  2314**
 236001 Incluido 236001 Included	MANILLON + UÑERO ATRIA CON BOCALLAVE ATRIA HANDLE + FINGER GRIP WITH KEYHOLE	2305**  2315**
	MANILLON + UÑERO ATRIA SIN BOCALLAVE ATRIA HANDLE + FINGER GRIP WITHOUT KEYHOLE	2306**  2316**
 (3)	UÑERO ATRIA ATRIA FINGER GRIP	2320**

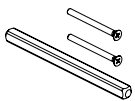
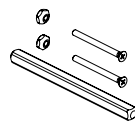
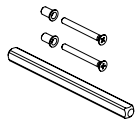

**Acabados
 **Finishes

KITS DE FIJACION FIXATION KITS		
	KIT FIJACION MANILLA + UÑERO HANDLE + FINGER GRIP FASTENING KIT	236001
	KIT FIJACIÓN DOBLE MANILLA DOUBLE HANDLE FASTENING KIT	236002
	KIT FIJACION MANILLA SIMPLE + INSERTOS ROSCADOS HANDLE + THREADED INSERTS FASTENING KIT	236003

FRENTE FALLEBA DRIVE GEAR			
	H	ALTO DE HOJA SASH HEIGHT	REF.
	2100 mm	1800 - 2200	234001
	2400 mm	2201 - 2500	234002
	2700 mm	2501 - 2800	234003
	EMBELLECEDOR DRIVE COVER		234010
	CONJUNTO ALARGADOR 500 mm 500 mm GEAR EXTENSION		234011
CALZOS PARA FRENTE FALLEBA DRIVE GEAR WEDGES			
	CALZO FALLEBA DRIVE GEAR WEDGE	14 mm	235001
		17 mm	235002
		15,5 mm	235003
		18 mm	235004
		21 mm	235005
	CALZO CARRO PRINCIPAL FRONT BOGIE WEDGE	17 mm	235101
		14 mm	235102
		15,5 mm	235103
		18 mm	235104
		21 mm	235105
	KIT DE CALZOS FRONTALES FRONT WEDGES KIT	14 mm	235201
		17 mm	235202
		15,5 mm	235203
		18 mm	235204
		21 mm	235205

*La altura de los calzos de aluminio es adaptable al perfil.

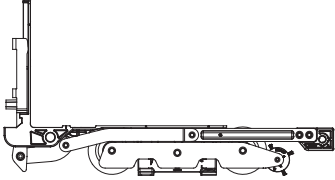
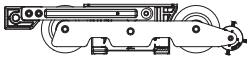
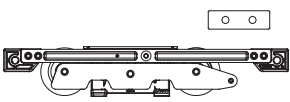
*The Aluminium wedge height is adaptive to any profile.

CARROS BOGIES		
	CARRO PRINCIPAL FRONT BOGIE	REF.
		233001
	CARRO TRASERO REAR BOGIE	233002
	CARRO INTERMEDIO INTERMEDIATE BOGIE	233003
	SOPOTE HOJA FIJA FIXED LEAD SUPPORT	233004

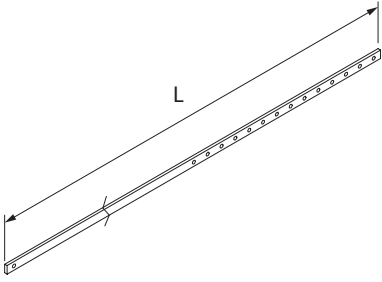
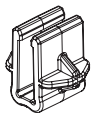
PLETINA CARROS CONNECTING ROD					
	L	ANCHO DE HOJA <300Kg SASH WIDTH	ANCHO DE HOJA >300Kg SASH WIDTH	CALZOS WEDGES	REF.
	756 mm	950 - 1300	1450 - 1800	1	233013
	1260 mm	1301 - 1800	1801 - 2300	2	233012
	1760 mm	1801 - 2300	2301 - 2800	3	233011
	2760 mm	2301 - 3300	2801 - 3800	6	233010
	CALZO PLETINA* CONNECTING ROD WEDGE				0423071

*Se incluyen 3 calzos para las pletinas en los Kits de cerraderos 234101 y 234102. (Pag.12)

*3 connecting rod wedges are included with the closing point Kits 234101 and 234102. (Pag.12)

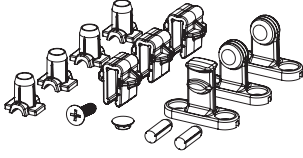
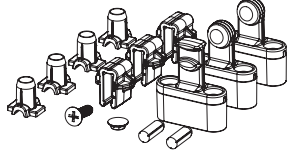
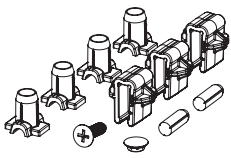
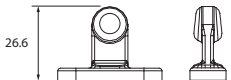
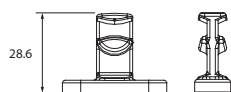
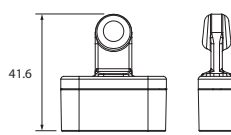
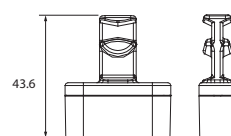
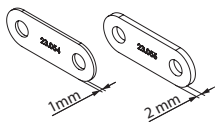
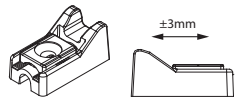
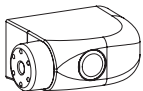
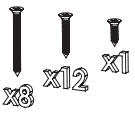
PUNTOS DE CIERRE Y ACCESORIOS LOCKING POINTS AND ACCESSORIES			
	KIT DE CERRADEROS LOCKING POINT KIT	234101	
	KIT DE CERRADEROS (+CALZO 15mm) LOCKING POINT KIT (+WEDGE 15mm)	234102	
	KIT DE ACCESORIOS HOJA INTERMEDIA ACCESSORIES KIT FOR INTERMEDIATE SASH	234103	
	CERRADERO LOCKING POINT	234020	
	CERRADERO MICROVENTILACIÓN MICROVENTILATION LOCKING POINT	234021	
	CERRADERO + CALZO 15mm LOCKING POINT + WEDGE 15mm	234023	
	CERRADERO MICROVENTILACIÓN + CALZO 15mm MICROVENTILATION LOCKING POINT + WEDGE 15mm	234024	
	CALZO PUNTO DE CIERRE 1mm LOCKING POINT WEDGE 1mm	23054	
	CALZO PUNTO DE CIERRE 2mm LOCKING POINT WEDGE 2mm	23055	
	CERRADERO HORIZONTAL FRAME LOCK POINT	234022	
	TOPE FIN DE CARRERA STOPPER	Blanco White	234025
		Negro Black	234026
	KIT TORNILLERÍA SCREWS KIT	Para calzos < 18 mm For wedges < 18 mm	236004
		Para calzos > 18mm For wedges > 18 mm	236005

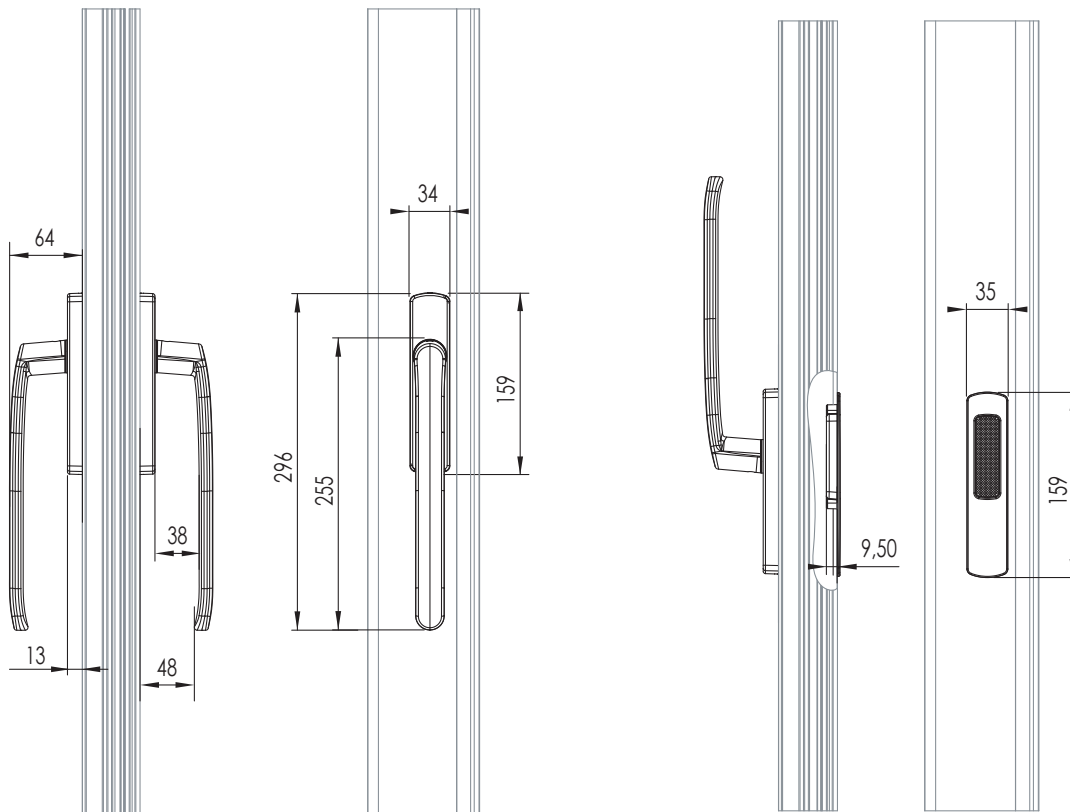
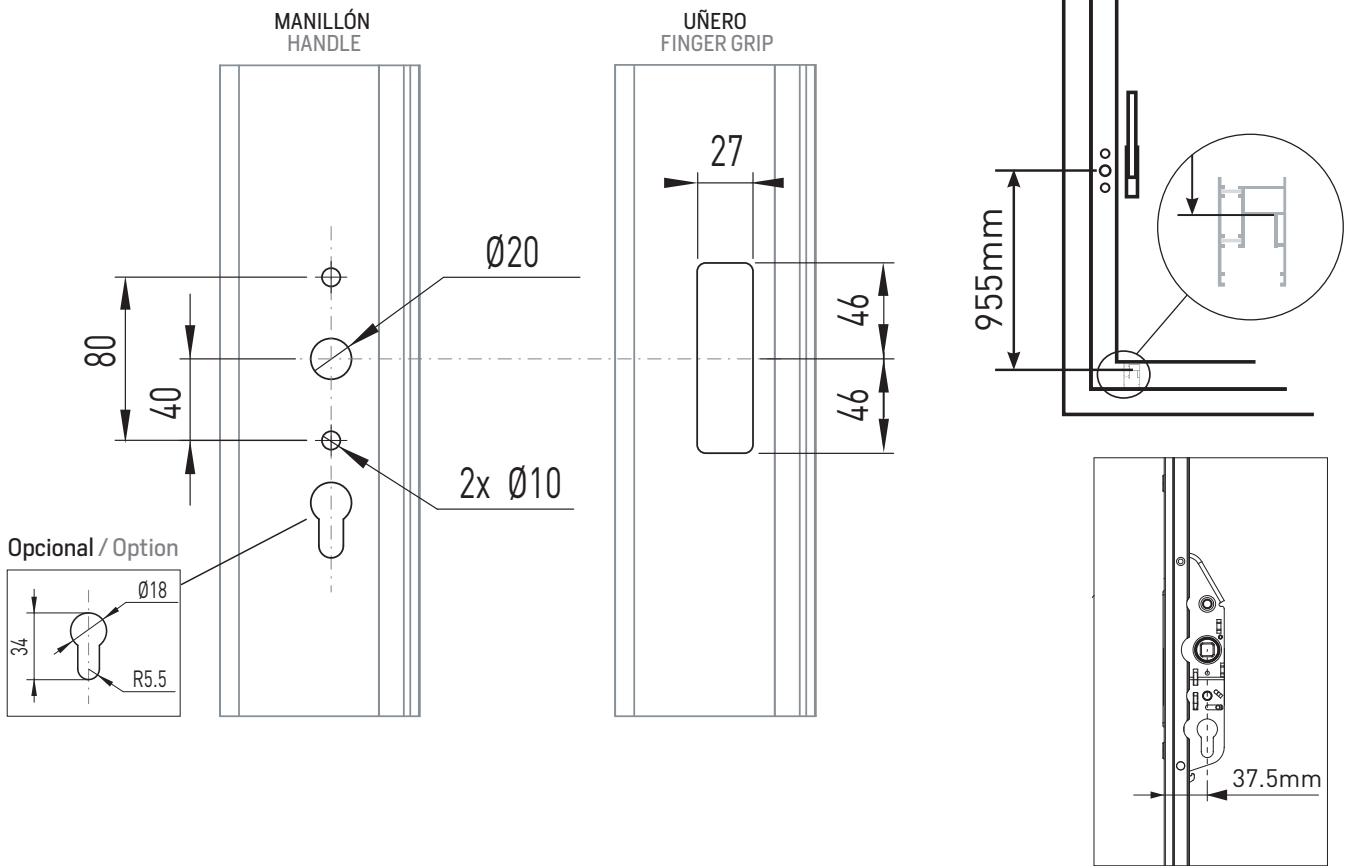

MONTAJE DEL MANILLON
 HANDLE ASSEMBLY

MANILLON + UÑERO
 HANDLE + FINGER GRIP

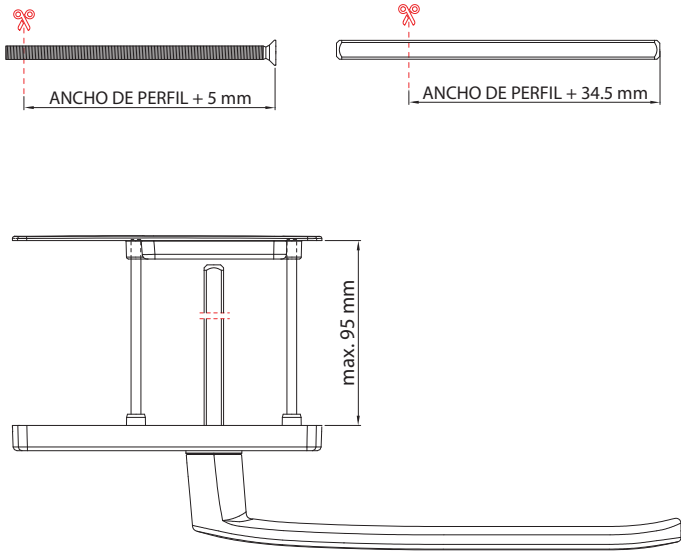

DOBLE MANILLON ATRIA
 ATRIA DOUBLE HANDLE

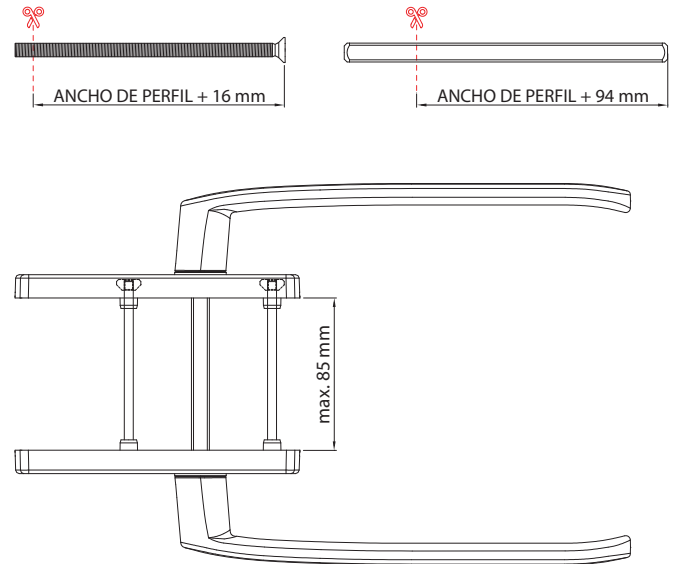

MONTAJE DEL BOMBILLO
 CYLINDER ASSEMBLY

MANILLON + UÑERO
 HANDLE + FINGER GRIP

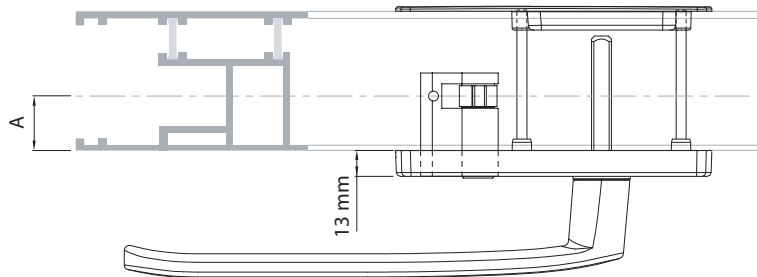
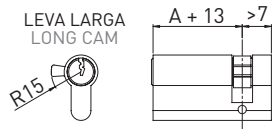

DOBLE MANILLON ATRIA
 ATRIA DOUBLE HANDLE

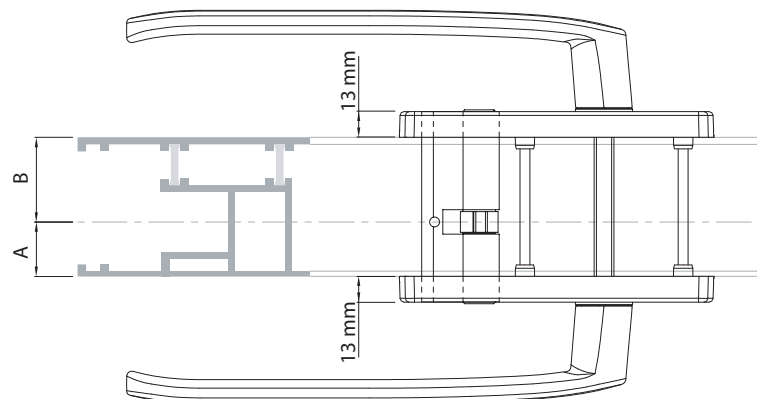
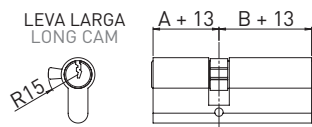

A. MONTAJE DE LOS CARROS
 BOGIES ASSEMBLY

PASO STEP 1 PREMONTAR CARROS Y PLETINA
 PREASSEMBLE BOGIES WITH
 THE OPERATING ROD

PASO STEP 2 FIJAR LOS CARROS AL PERFIL
 FIX THE BOGIES TO PROFILE

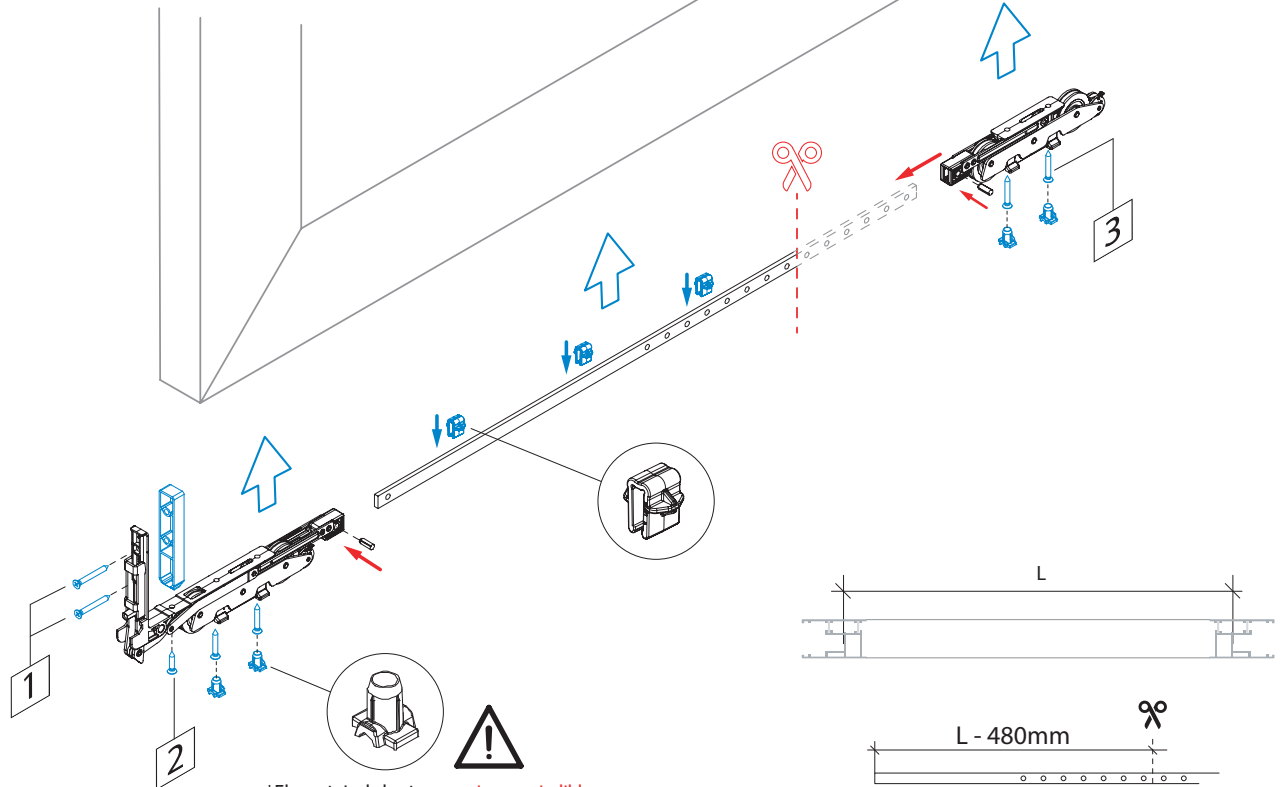

*El montaje de los topes es **imprescindible**.
 Stac no garantiza el correcto funcionamiento del
 herraje si no se montan estas piezas.
 *The assembly of this caps is **indispensable**.
 Stac will not guarantee the proper functioning of
 the hardware if this parts are no assembled.

	CANTIDAD	DESCRIPCION	MEDIDAS [mm]
1	2 uds.	DIN 7982	4,8x32*
2	1 ud.	DIN 7982	4.8x19
3	4 uds. [<300Kg] 8 uds. [>300Kg]	DIN 7982	4,8x32

*4.8x50 - Para calzos de falleba < 18mm
 4.8x60 - Para calzos de falleba > 18mm
 *4.8x50 - With drive gear wedges < 18mm
 4.8x60 - With drive gear wedges > 18mm

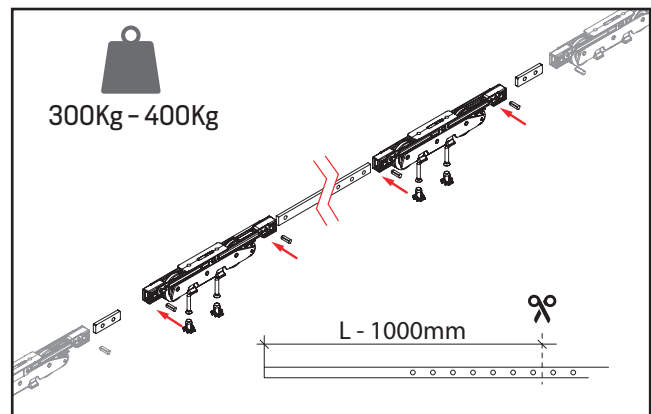

Para más de 300Kg (Max.400Kg) preensamblar
 2 carros intermedios en el **paso 1**.
 For more than 300Kg (Max.400Kg) preassemble
 2 intermediate bogies in the **step 1**.

B. MONTAJE DEL FRENTE FALLEBA DRIVE GEAR ASSEMBLY

PASO STEP 1 PREMONTAR CALZOS EN LA FALLEBA
 PREASSEMBLE WEDGES ON DRIVE GEAR

PASO STEP 2 FIJAR LA FALLEBA AL PERFIL
 FIX THE DRIVE GEAR TO PROFILE

	CANTIDAD	DESCRIPCION	MEDIDAS [mm]
1	8 uds.	DIN 7982	4,8x50 / 4.8x60*
2	1 ud.	DIN 7982 4.8x19 Incluido en / Included in 234101 - 234102 - 234103	

*4.8x50 - Para calzos de falleba < 18mm
 4.8x60 - Para calzos de falleba > 18mm
 *4.8x50 - With drive gear wedges < 18mm
 4.8x60 - With drive gear wedges > 18mm

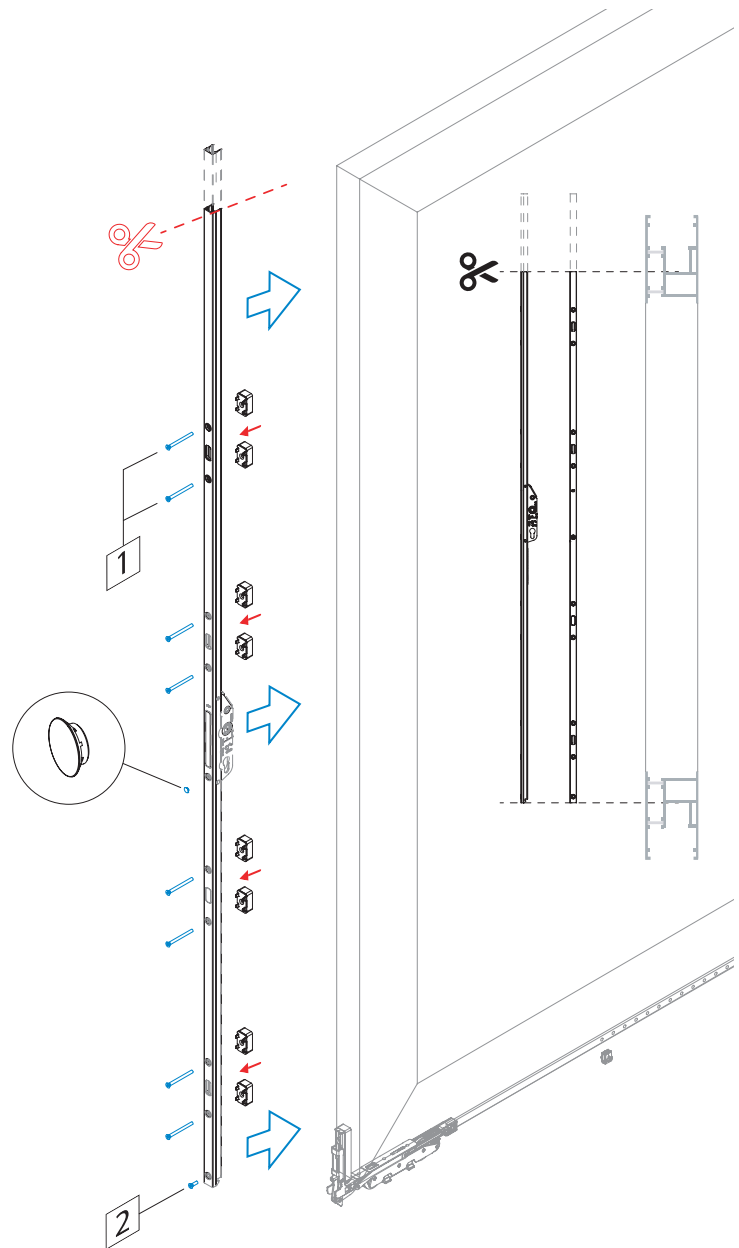

MONTAJE DEL CONJUNTO ALARGADOR GEAR EXTENSION ASSEMBLY

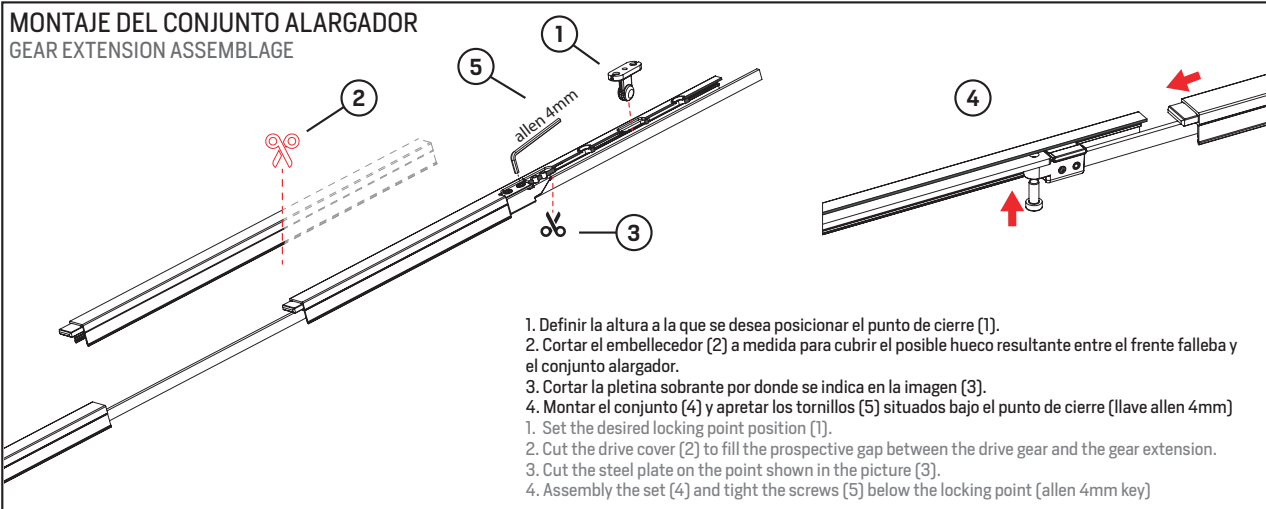

C. PUNTOS DE CIERRE Y ACCESORIOS
 LOCKING POINTS AND ACCESSORIES

POSICION PUNTOS DE CIERRE.
 LOCKING POINTS POSITION

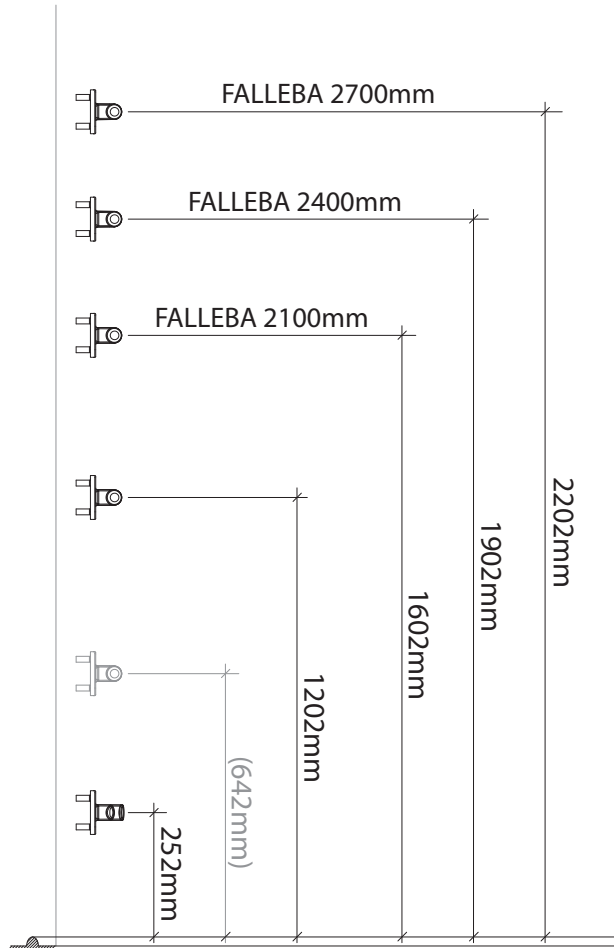

[*] Punto de cierre opcional
 [*] Optional locking point

DIN 7982 4.8x32mm

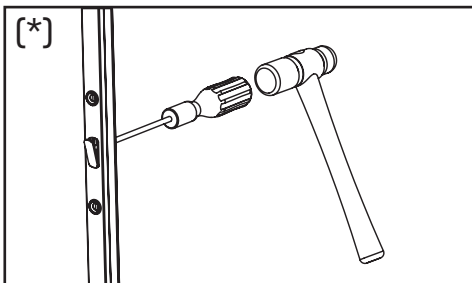

MONTAJE DEL TOPE FIN DE CARRERA
 STOPPER ASSEMBLY

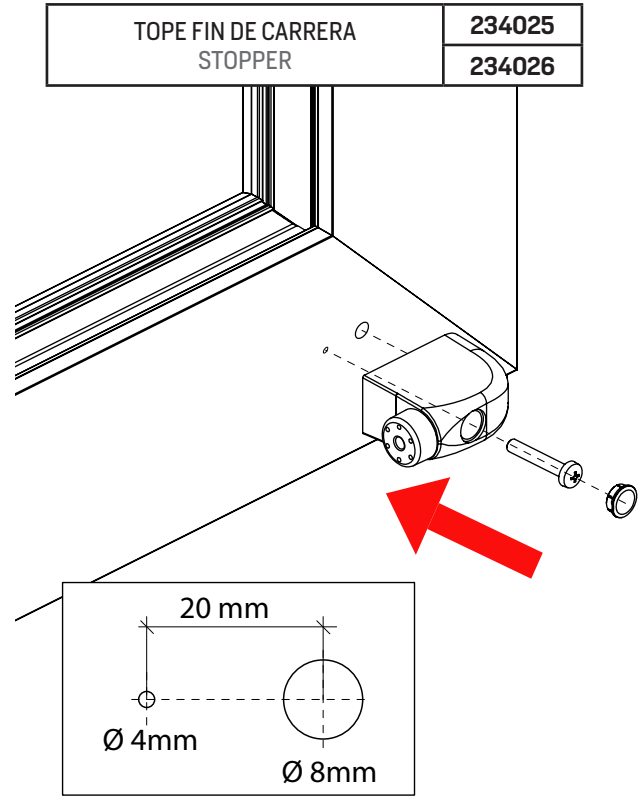

MONTAJE PUNTO DE CIERRE HORIZONTAL
 FRAME LOCK POINT ASSEMBLY

CERRADERO HORIZONTAL FRAME LOCK POINT	234022
--	--------

