

TÍTULO

CATÁLOGO TÉCNICO ELEVABLE LS200

DESCRIPCIÓN

Este documento detalla las posibles configuraciones para corredera elevable teniendo en cuenta medidas, pesos y demás condicionantes de este tipo de aperturas.

OBSERVACIONES

Edición 01: Septiembre 2018

NORMATIVA DE REFERENCIA

UNE-EN 13126-16:2008 - Herrajes para la edificación. Requisitos y métodos de ensayo de ventanas y puertas balconeras.
Parte 16: Herrajes para dispositivos de elevación y deslizamiento de puertas y ventanas.

Las observaciones a este documento han de dirigirse a:

STAC Sistemas Técnicos del Accesorio y Componentes, S.L.

Polígono Industrial Picusa s/n
15900 - Padrón, A Coruña - España

T +34 981 817 036
F +34 981 817 037
stac.es

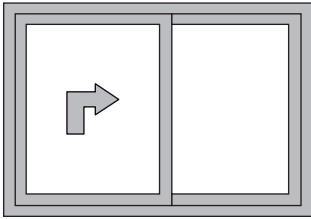

■ **CONFIGURACIÓN < 200 kg | < 200 kg CONFIGURATION**

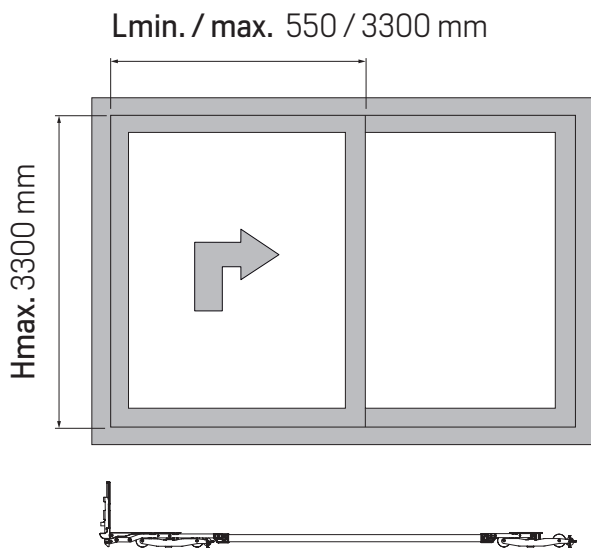

■ **CONFIGURACIÓN 200 - 250 kg | 200- 250 kg CONFIGURATION**

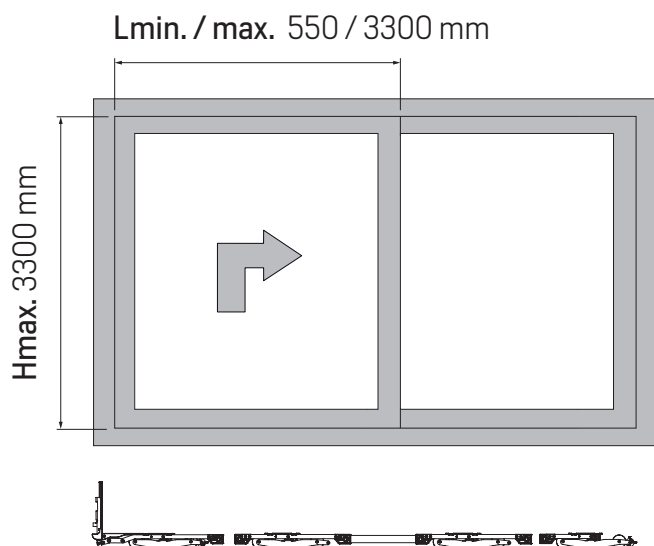

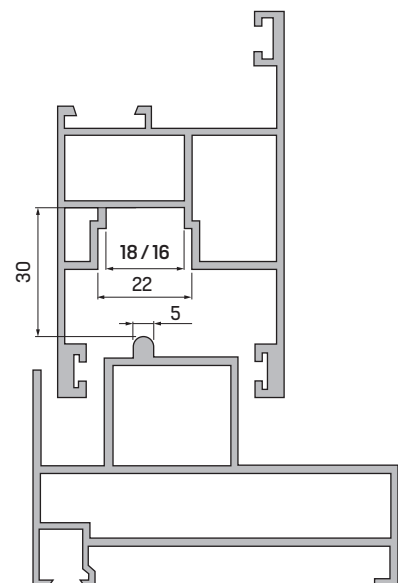
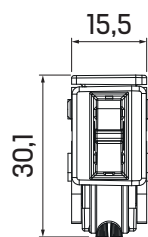
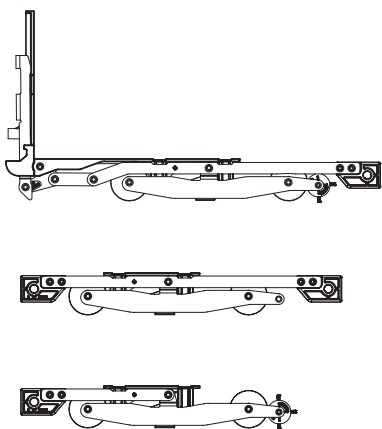
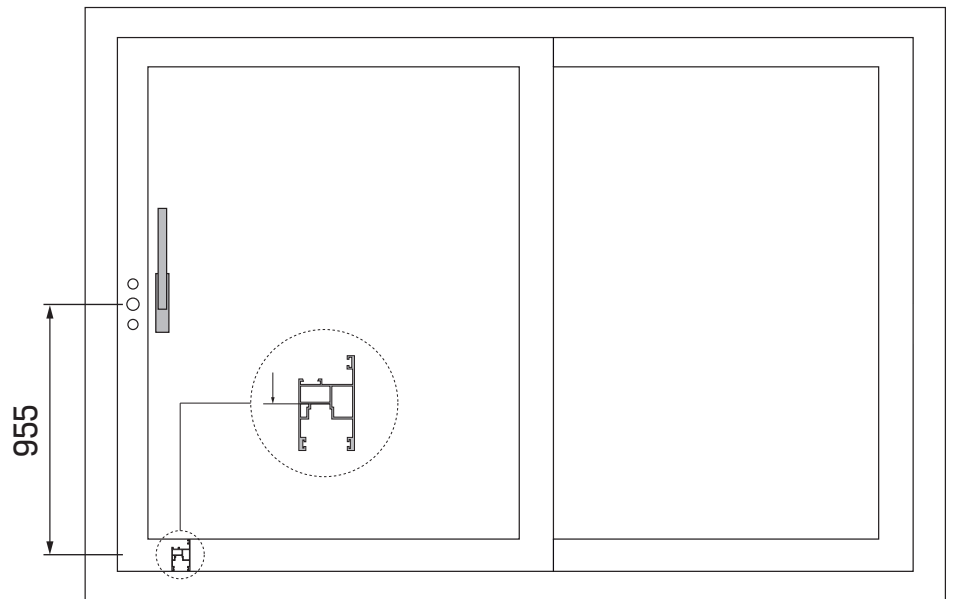
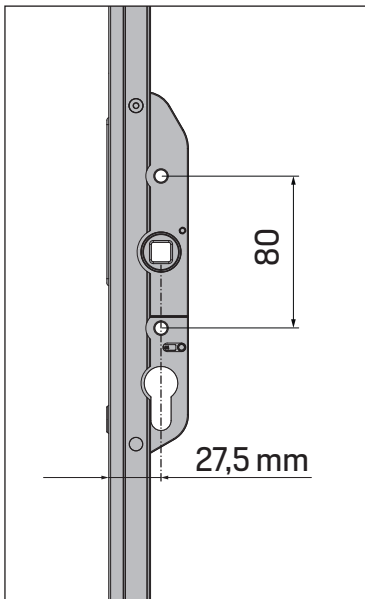

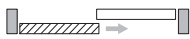

ESQUEMA
 DIAGRAM **A**

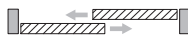
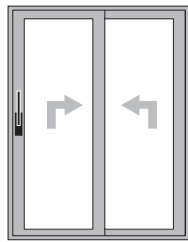

ESQUEMA
 DIAGRAM **B**

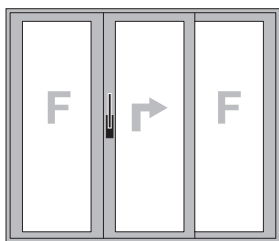

ESQUEMA
 DIAGRAM **C**

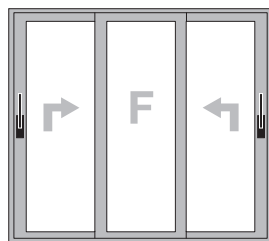

ESQUEMA
 DIAGRAM **D**

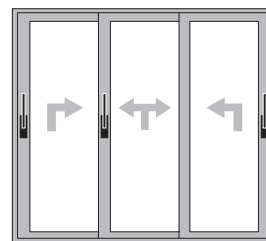

ESQUEMA
 DIAGRAM **G**

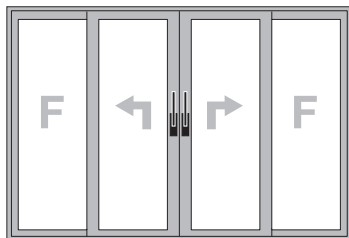

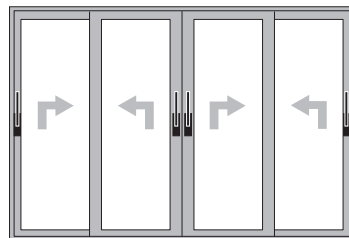

ESQUEMA
 DIAGRAM **E**

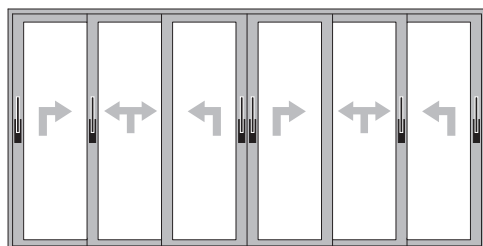

ESQUEMA
 DIAGRAM **F**



ESQUEMA
 DIAGRAM **H**

-  HOJA PRINCIPAL | MAIN SASH
-  HOJA INTERMEDIA | INTERMEDIATE SASH
-  HOJA FIJA | FIXED SASH

REF.	DESCRIPCIÓN DESCRIPTION		VER ESQUEMA SEE DIAGRAM							
			A	B	C	D	E	F	G	H
			UNIDADES UNITS							
Ver tabla de manillas See handles table	MANILLA DOBLE MANILLA MANILLA - UÑERO HANDLE DOUBLE HANDLE HANDLE - FINGER GRIP		1	2	1	2	2	4	3	6
233501	CARRO DELANTERO FRONT BOGIE		1	2	1	2	2	4	3	6
233502	CARRO TRASERO REAR BOGIE		1	2	1	2	2	4	3	6
233504	CARRO FIJO FIXED BOGIE		2	-	4	2	4	-	-	-
233010	PLETINA CONEXIÓN CARROS BOGIE CONNECTING ROD	2760 mm	1	2	1	2	2	4	3	6
233011		1760 mm								
233012		1260 mm								
233013		756 mm								
234501	FRENTE FALLEBA FRONT OPERATING ROD	1800 - 2100 mm	1	2	1	2	1+1*	3+1*	2+1*	3+3*
234502		2101 - 2400 mm								
234503		2401 - 2700mm								
234301	KIT CERRADEROS LOCKING KIT	CORTOS SHORT								
234302		LARGOS LARGE								
234303	KIT ELEMENTOS COMUNES COMMON ELEMENTS KIT		-	-	-	-	1	1	1	3
234322	CERRADERO HORIZONTAL FRAME LOCK POINT		-	-	-	-	1	1	1	3
234025	TOPE FIN DE CARRERA STOPPER	BLANCO WHITE	(1)	(1)	(1)	(2)	(2)	(2)	(2)	(4)
234026		NEGRO BLACK								

PARA HOJAS DE MÁS DE 200 kg | FOR SASHES MORE THAN 200 kg

233503	CARRO SUPLEMENTARIO SUPPLEMENTARY BOGIE	2 por cada hoja elevable 2 per lift sash
233504	CARRO FIJO FIXED BOGIE	2 por cada hoja fija 2 per fixed size

[*] Opcional | Optional

- Para las hojas intermedias siempre se puede instalar la falleba más corta 234501 | For intermediate sash is always possible to install the shortest operating rod 234501
- Disponibles kits de tornillería. Consultar disponibilidad por serie | Screws kit are available. Consult availability per serie.

SELECCIÓN DE PLETINA DE CONEXIÓN ENTRE CARROS | BOGIES CONNECTING ROD SELECTION

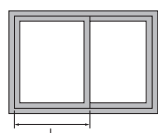

REF.	L (mm)	550-1300	1301-1800	1801-2300	2301-3300	1050-1800	1801-2300	2301-2800	2801-3800
233013	756 mm	1	-	-	-	1	-	-	-
233012	1260 mm	-	1	-	-	-	1	-	-
233011	1760 mm	-	-	1	-	-	-	1	-
233010	2760 mm	-	-	-	1	-	-	-	1

SELECCIÓN DE FRENTE FALLEBA | FRONT OPERATING ROD SELECTION



3 - 4 PUNTOS DE CIERRE
3 - 4 LOCKING POINTS

4 - 5 PUNTOS DE CIERRE
4 - 5 LOCKING POINTS

REF.	H (mm)	1800-2200	2201-2500	2501-2800	2801-3300	2081-3300
234501	FRENTE FALLEBA 2100 mm FRONT OPERATING ROD 2100 mm	1	-	-	-	-
234502	FRENTE FALLEBA 2400 mm FRONT OPERATING ROD 2400 mm	-	1	-	-	-
234503	FRENTE FALLEBA 2700 mm FRONT OPERATING ROD 2700 mm	-	-	1	1	1
234010	PROLONGADOR 500 mm SIN PTO. DE CIERRE 500 mm EXTENSION ROD WITHOUT LOCKING POINT	-	-	-	1	-
A234011	PROLONGADOR 500 mm CON PTO. DE CIERRE 500 mm EXTENSION ROD WITH LOCKING POINT	-	-	-	-	1
234020	CERRADERO* LOCKING POINT*	SIN CALZO WITHOUT WEDGE				1-2
234023		CON CALZO WITH WEDGE				

* Los kits 234301 y 234302 incluyen 3 puntos de cierre. Para añadir un punto de cierre adicional se pedirá una de las referencias de la tabla.

* The kits 234301 and 234302 include 3 locking points. To include another one, will be required one of the references in table.

- El frente falleba incluye 3 puntos de cierre abiertos con la posibilidad de abrir un punto de cierre adicional (más información en la página 14).

- The front operating rod allows 3 locking points, with the possibility of enable one more (more information in page 14).

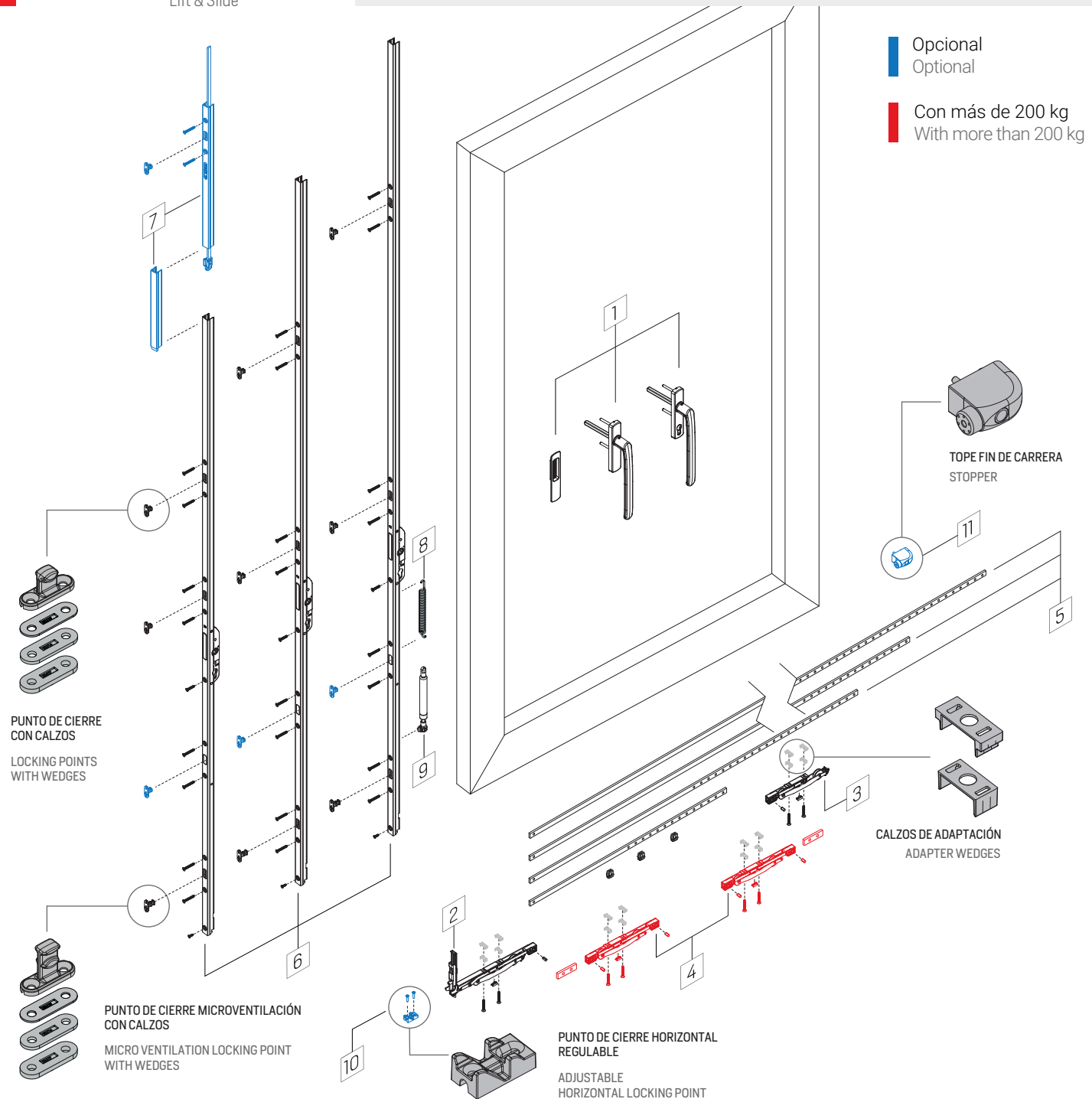

1	Manillón ATRIA ATRIA handle	P.8
2	Carro delantero Front bogie	233501
3	Carro trasero Rear bogie	233502
4	Carro suplementario Supplementary bogie	233503
5	Pletina conexión carros 2760 mm 2760 mm bogie connecting rod	233010
	Pletina conexión carros 1760 mm 1760 mm bogie connecting rod	233011
	Pletina conexión carros 1260 mm 1260 mm bogie connecting rod	233012
	Pletina conexión carros 756 mm 756 mm bogie connecting rod	233013

6	Frente falleba 2100 mm 2100 mm front operating rod	234501
6	Frente falleba 2400 mm 2400 mm front operating rod	234502
6	Frente falleba 2700 mm 2700 mm front operating rod	234503
7	Prolongador 500 mm sin pto. de cierre 500 mm extension rod without locking point	234010
	Prolongador 500 mm con pto. de cierre 500 mm extension rod with locking point	A234011
8	Resorte compensador peso Weight compensating spring	237001
9	Cilindro amortiguador SOFT-LIFT SOFT-LIFT damping cylinder	237002
10	Punto de cierre horizontal Horizontal locking point	234322

11	Tope fin de carrera blanco White stopper	234025
	Tope fin de carrera negro Black stopper	234026
Página 11 Page 11	Kit cerradero corto + Calzos Short locking point + Wedges	234320
	Cerradero + Calzos Locking point + Wedges	A234020
	Cerradero MV corto + Calzos Short MV locking point + Wedges	234321
	Cerradero MV + Calzos MV locking point + Wedges	A234021
	Kit de tornillería LS200 LS200 Screw kit	236007
	Kit de elementos comunes LS200 LS200 common elements kit	234303

MANILLÓN ATRIA ATRIA HANDLE		
 <p>236001 Incluido Included</p>	<p>MANILLÓN ATRIA CON BOCALLAVE (1) ATRIA HANDLE WITH KEYHOLE (1)</p>	 2311**
	<p>MANILLÓN ATRIA SIN BOCALLAVE (2) ATRIA HANDLE WITHOUT KEYHOLE (2)</p>	 2312**
 <p>236002 Incluido Included</p>	<p>JUEGO MANILLÓN ATRIA CON BOCALLAVE ATRIA HANDLE SET WITH KEYHOLE</p>	 2313**
	<p>JUEGO MANILLÓN ATRIA SIN BOCALLAVE ATRIA HANDLE SET WITHOUT KEYHOLE</p>	 2314**
 <p>236001 Incluido Included</p>	<p>MANILLÓN + UÑERO ATRIA CON BOCALLAVE ATRIA HANDLE + FINGER GRIP WITH KEYHOLE</p>	 2315**
	<p>MANILLÓN + UÑERO ATRIA SIN BOCALLAVE ATRIA HANDLE + FINGER GRIP WITHOUT KEYHOLE</p>	 2316**
	<p>UÑERO ATRIA ATRIA FINGER GRIP</p>	<p>2320**</p>





Manillón desmontable
 Detachable handle

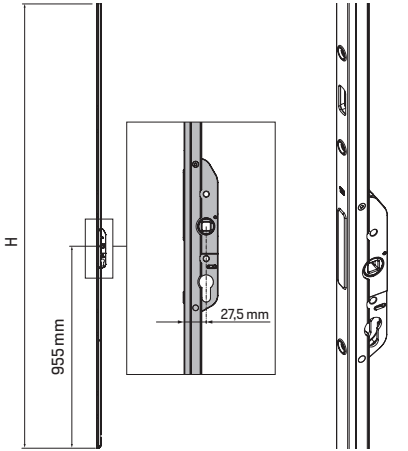

** Acabados
 Finishes

KITS DE FIJACIÓN FIXATION KITS		
	KIT FIJACIÓN MANILLA + UÑERO HANDLE + FINGER GRIP FASTENING KIT	236001
	KIT FIJACIÓN DOBLE MANILLA DOUBLE HANDLE FASTENING KIT	236002
	KIT FIJACIÓN MANILLA SIMPLE + INSERTOS ROSCADOS HANDLE + THREADED INSERTS FASTENING KIT	236003



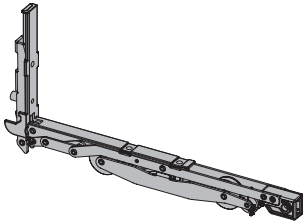
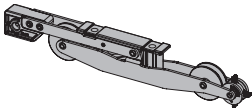
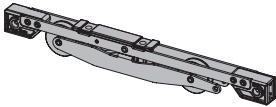
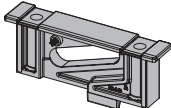

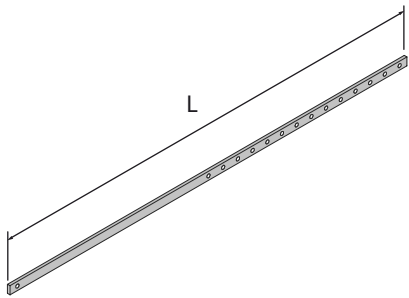
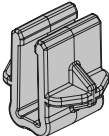
FRETE FALLEBA FRONT OPERATING ROD			
	H	ALTO DE HOJA SASH HEIGHT	REF.
	2100	1800 - 2200	234501
	2400	2201 - 2500	234502
	2700	2501 - 2800	234503
	PROLONGADOR 500 mm SIN PUNTO DE CIERRE 500 mm EXTENSION ROD WITHOUT LOCKING POINT	234010	
	PROLONGADOR 500 mm CON PUNTO DE CIERRE 500 mm EXTENSION ROD WITH LOCKING POINT	A234011	

CARROS BOGIES		
	CARRO DELANTERO FRONT BOGIE	233501
	CARRO TRASERO REAR BOGIE	233502
	CARRO SUPLEMENTARIO SUPPLEMENTARY BOGIE	233503
	CARRO FIJO FIXED BOGIE	233504

PLETINA DE CONEXIÓN ENTRE CARROS BOGIE CONNECTING ROD					
	L	ANCHO DE HOJA < 200 kg WIDTH SASH < 200 kg	ANCHO DE HOJA > 250 kg WIDTH SASH > 250 kg	CALZOS WEDGES	REF
	756 mm	950 - 1300	1450 - 1800	1	233013
	1260 mm	1301 - 1800	1801 - 2300	2	233012
	1760 mm	1801 - 2300	2301 - 2800	3	233011
	2760 mm	2301 - 3300	2801 - 3800	6	233010
	CALZO PLETINA* CONNECTING ROD WEDGE*				0423071

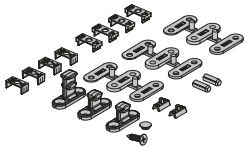
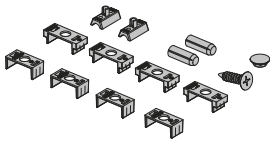
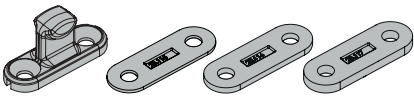
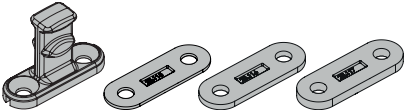
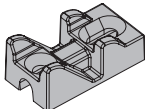
* Se incluyen 3 calzos para las pletinas en los kits de cerraderos 234101 y 234102 (Página 13).

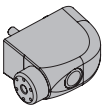
* 3 connecting rod wedges are included with the closing point kits 234101 and 234102 (Page 13).

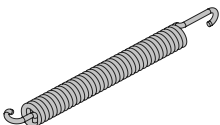
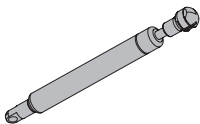
PUNTOS DE CIERRE Y ACCESORIOS LOCKING POINTS & ACCESSORIES		
	KIT DE CERRADEROS CORTOS SHORT LOCKING POINT KIT	234301
	KIT DE CERRADEROS LARGOS LARGE LOCKING POINT KIT	234302
	KIT ELEMENTOS COMUNES LS200 LS200 COMMON ELEMENTS KIT	234303
	CERRADERO CORTO + CALZOS (1+2+3 mm) SHORT LOCKING POINT + WEDGES (1+2+3 mm)	234320
	CERRADERO + CALZOS (1+2+3 mm) LOCKING POINT + WEDGES (1+2+3 mm)	A234020
	CERRADERO MV CORTO + CALZOS (1+2+3 mm) SHORT MV LOCKING POINT + WEDGES (1+2+3 mm)	234321
	CERRADERO MV + CALZOS (1+2+3 mm) MV LOCKING POINT + WEDGES (1+2+3 mm)	A234021
	CERRADERO HORIZONTAL FRAME LOCK POINT	234322
	KIT CALZOS PLÁSTICOS PLASTIC WEDGE KIT	234203
	TOPE FIN DE CARRERA BLANCO WHITE STOPPER	234025
	TOPE FIN DE CARRERA NEGRO BLACK STOPPER	234026
	KIT DE TORNILLERÍA LS200 LS200 SCREW KIT	236007
	RESORTE COMPENSADOR PESO WEIGHT COMPENSATING SPRING	237001
	CILINDRO AMORTIGUADOR SOFT LIFT SOFT LIFT DAMPING CYLINDER	237002

■ MECANIZADO DE LOS PERFILES | MACHINING PROFILES

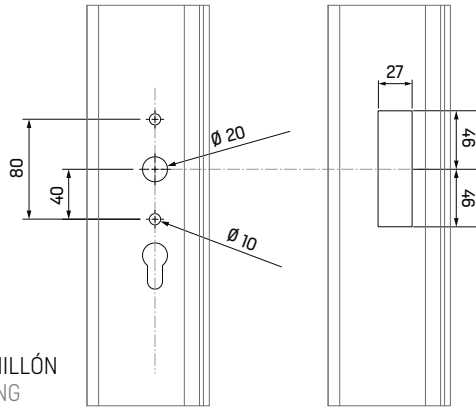

MECANIZADO MANILLÓN
 HANDLE MACHINING

MECANIZADO UÑERO
 FINGER GRIP MACHINING

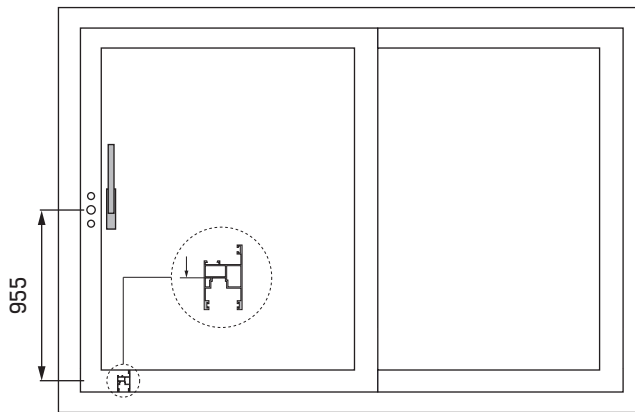
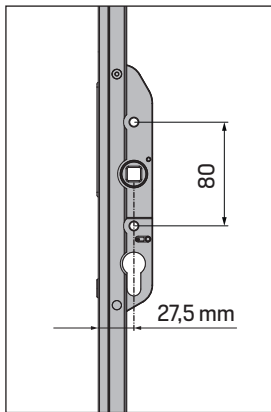

■ DIMENSIONES GENERALES | GENERAL DIMENSIONS

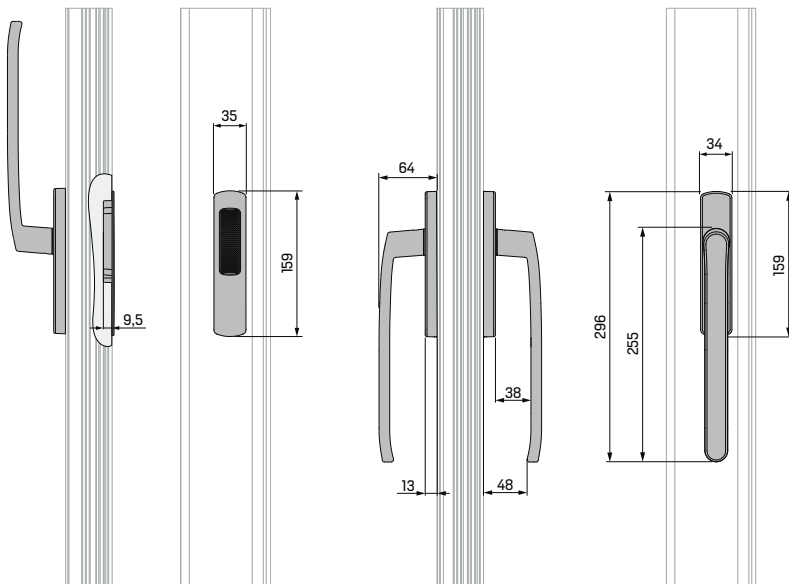

A. MONTAJE DE LOS CARROS BOGIES ASSEMBLY

CONFIGURACIÓN HOJA MÓVIL
MOBILE SASH CONFIGURATION

PASO STEP 1 PREMONTAR CARROS CON PLETINA
PRE-ASSEMBLY BOGIES WITH THE PLATE

PASO STEP 2 FIJAR LOS CARROS AL PERFIL
FIXING THE BOGIES TO THE PROFILE

CONFIGURACIÓN HOJA FIJA
FIXED SASH CONFIGURATION

PASO STEP 1 FIJAR LOS CARROS AL PERFIL
FIXING THE BOGIES TO THE PROFILE

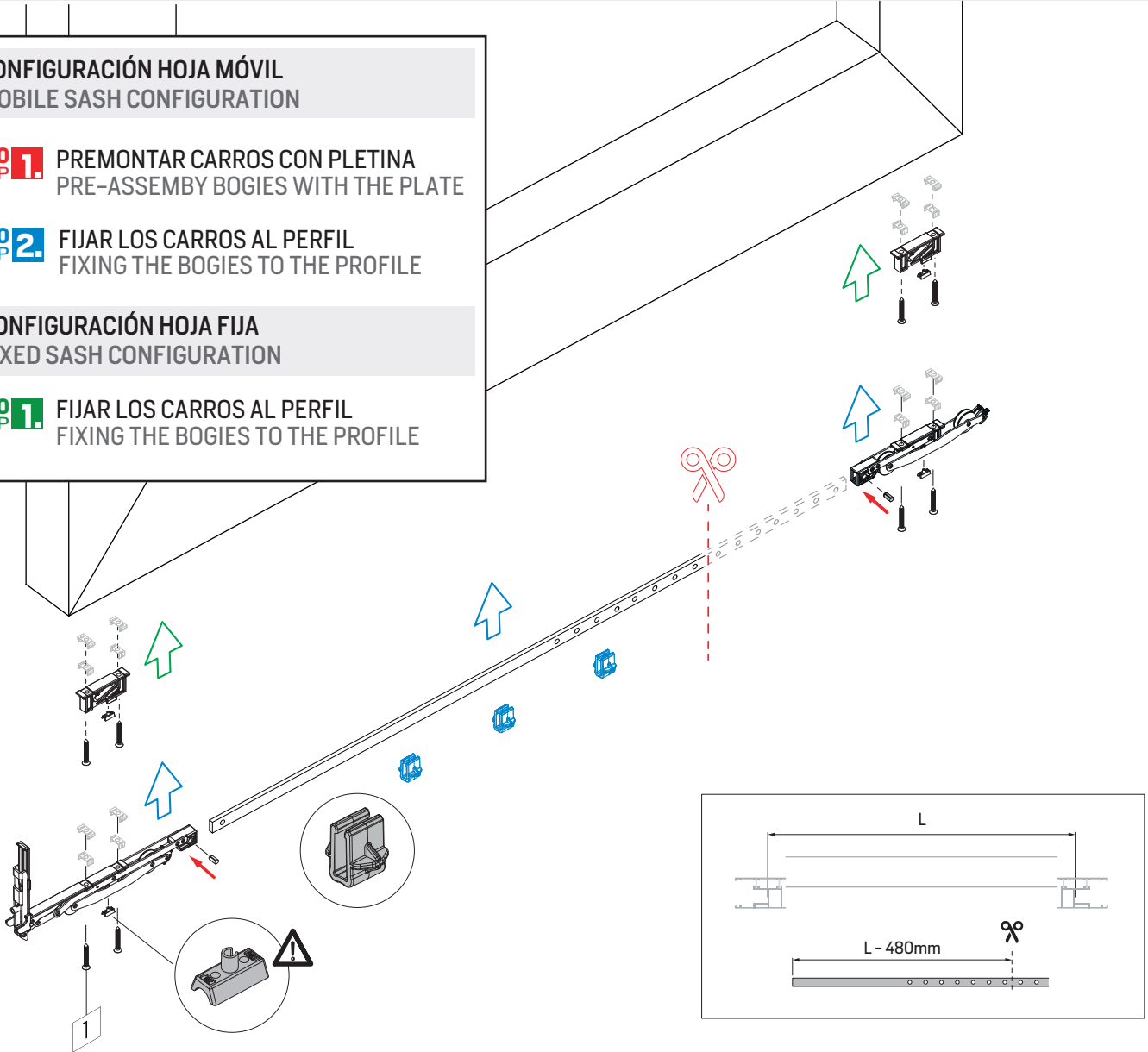

El montaje de los topes es **imprescindible**. STAC no garantiza el correcto funcionamiento del herraje si no se montan estas piezas.

The assembly of this caps is **indispensable**. STAC will not guarantee the proper functioning of the hardware if this parts are not assembled.

	CANTIDAD QUANTITY	DESCRIPCION DESCRIPTION	MEDIDAS DIMENSIONS
1	4 uds. (<200 kg) 8 uds. (>200 kg)	DIN 7982	4,8 x 38 mm (PH)

*Para calzos de falleba de más de 18mm de alto será necesario un tornillo más largo.

* For operating rod wedges over 18mm high, a longer screw is required.

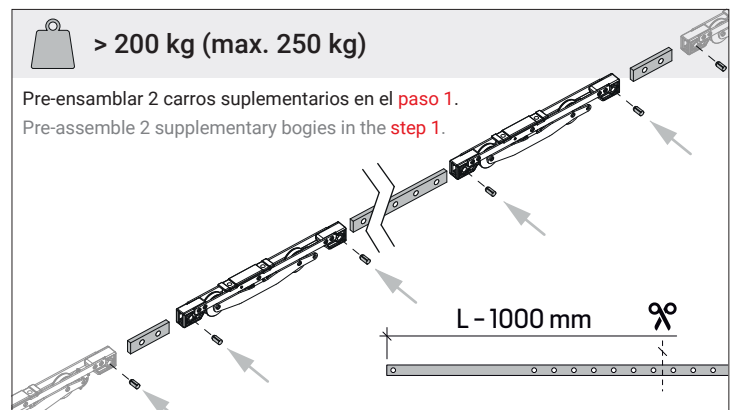

B. **MONTAJE DE FRENTE FALLEBA**
FRONT OPERATING ROD ASSEMBLY

PASO **1** **FIJAR LA FALLEBA AL PERFIL**
STEP **1** **FIX THE FRONT OPERATING ROD TO PROFILE**

	CANTIDAD QUANTITY	DESCRIPCION DESCRIPTION	MEDIDAS DIMENSIONS
1	8 uds. units	DIN 7982	4,8 x 38 mm (PH)
2*	1 ud. unit	DIN 7982	4,8 x 19 mm
3*	1 ud. unit		

*Incluidos en los KITS | Included in KITS 234301, 234302, 234303

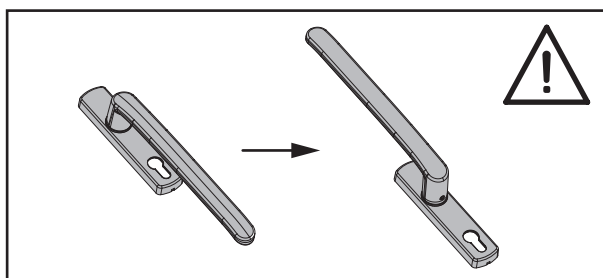
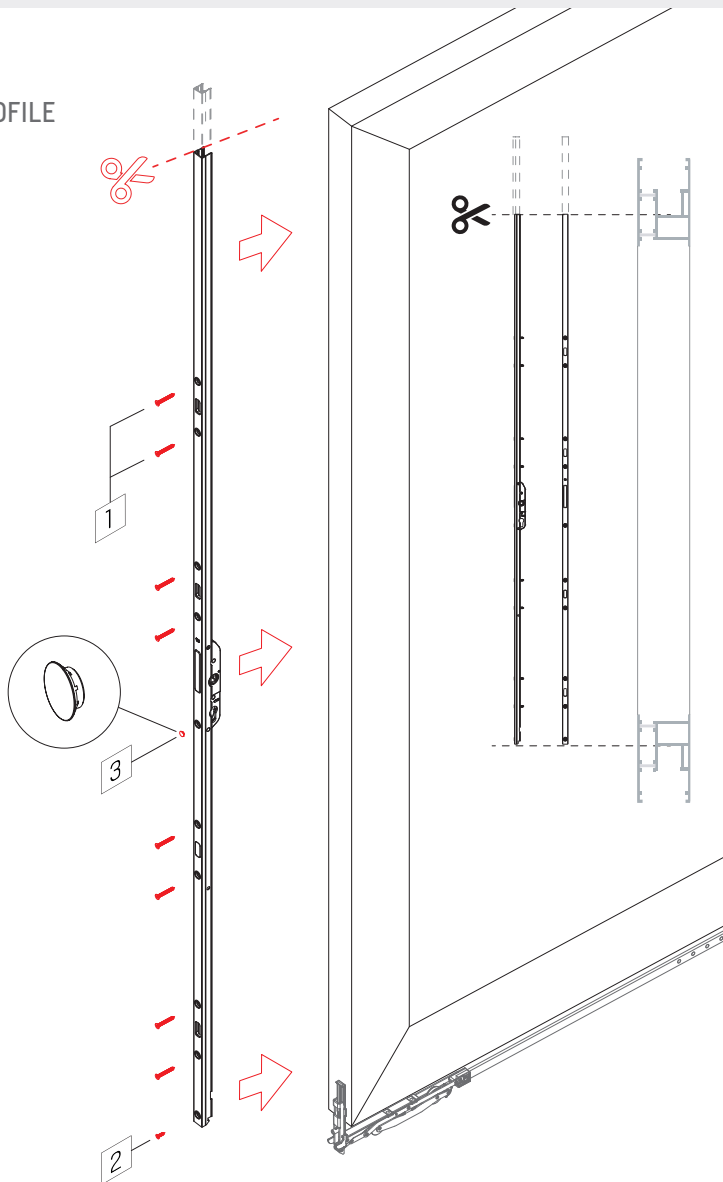

El montaje debe realizarse con el manillón en posición de **CERRADO**
 The installation must be done with the handle in **CLOSED** position

C. PUNTOS DE CIERRE Y ACCESORIOS
LOCKING POINTS & ACCESSORIES

POSICIÓN PUNTOS DE CIERRE
LOCKING POINTS POSITION

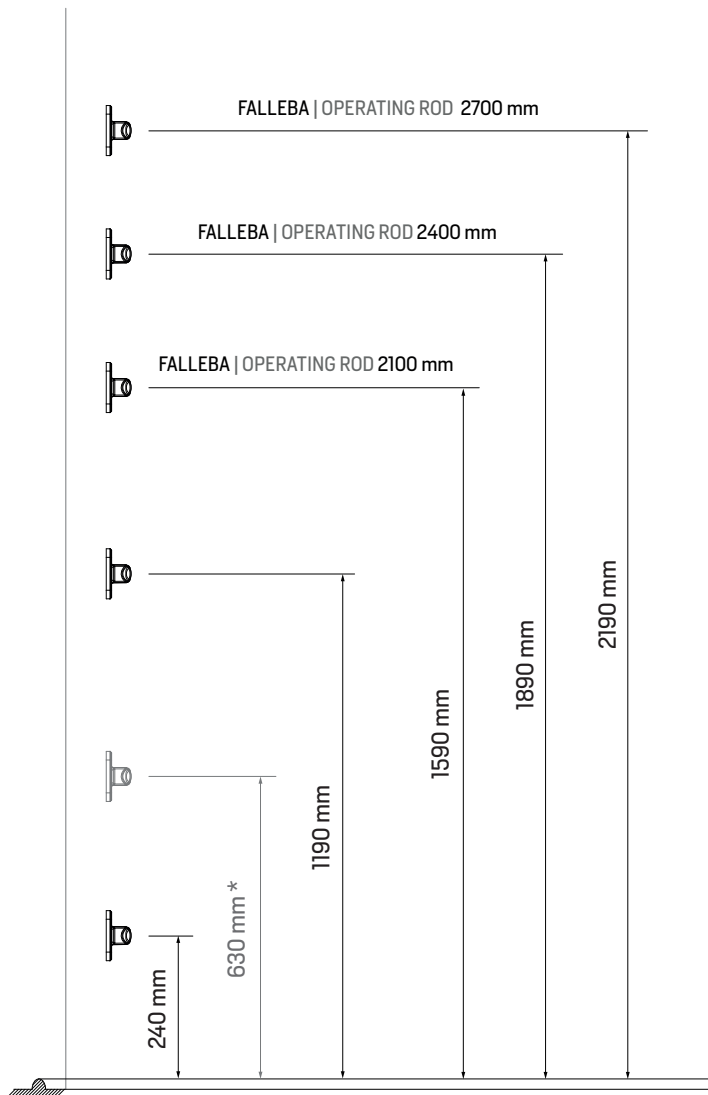

(*) Punto de cierre opcional
 (*) Optional locking point

DIN 7982 4.8 x 16 mm

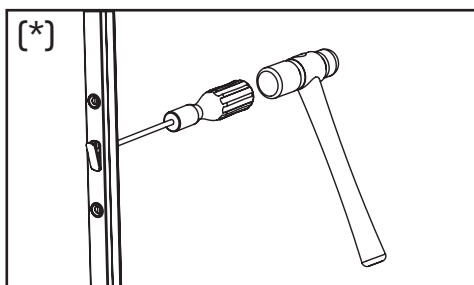

MONTAJE DEL TOPE FIN DE CARRERA
STOPPER ASSEMBLY

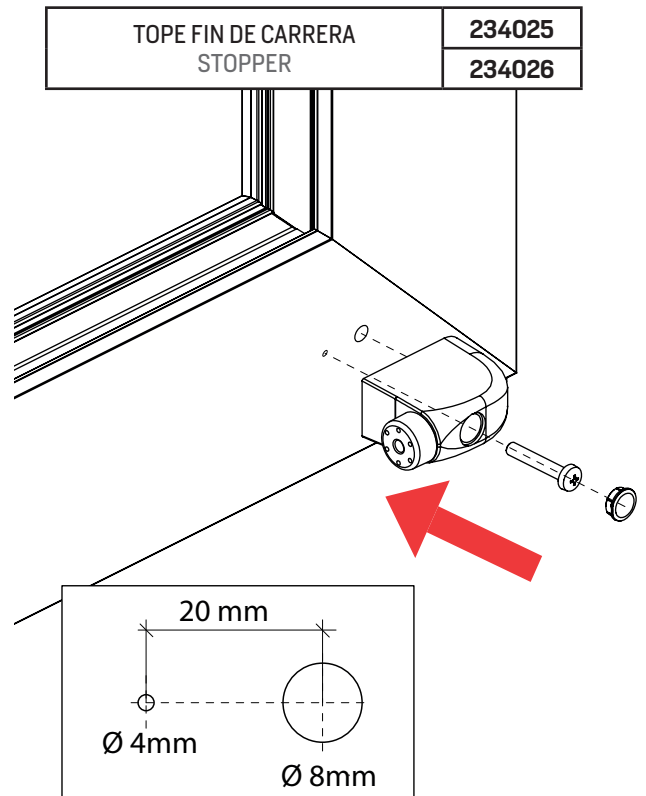

MONTAJE PUNTO DE CIERRE HORIZONTAL
FRAME LOCK POINT ASSEMBLY

CERRADERO HORIZONTAL FRAME LOCK POINT	234322
--	--------

