

RAL AN

Mod. Dep.

248 i

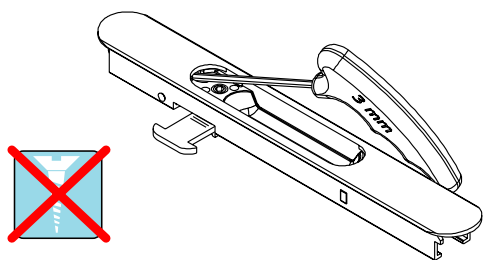

248 G

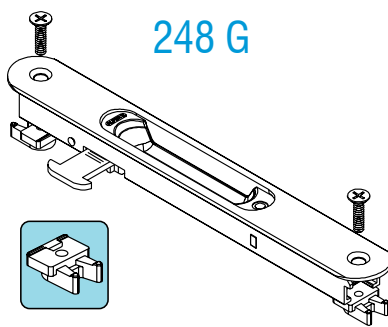

247

Recuperação automática
Automatic recovery
Recuperación automática
Récupération automatique



248

Recuperação manual
Manual recovery
Recuperación manual
Récupération manuelle



EMBALAGEM

Caixa com 25 unidades. 3185 grs.

MATERIAIS

Alumínio e zamak

FIXAÇÃO

Parafusos (incluídos)

ACABAMENTO

Lacado e anodizado

NORMAS

EN 1670, 13126-1

OBSERVAÇÕES

Fecho c/ recuperação manual.
Gancho não incluído

PACKAGING

Box with 25 units. 3185 grs.

MATERIALS

Aluminium and zamak

FIXING

Screws (included)

FINISHING

Powder painting and hard anodized

STANDARD

EN 1670, 13126-1

COMMENTS

Lock with manual recovery. Hook not included

EMPAQUETADO

Caja con 25 unidades. 3185 grs.

MATERIALES

Aluminio y zamak

FIJACIÓN

Tornillos (incluídos)

ACABADOS

Lacado y anodizado

NORMAS

EN 1670, 13126-1

OBSERVACIONES

Cierre con recuperación manual.
Gancho no incluído

EMBALLAGE

Boîte avec 25 pièces. 3185 grs.

MATÉRIELS

Aluminium et zamak

FIXATION

Vis (inclus)

FINITIONS

Laqué et anodisé

NORMATIF

EN 1670, 13126-1

OBSERVATIONS

Fermeture avec retablisement manuel.
Crochet pas inclus