

## SQUADRETTA AD AGGANCO ESTERNO

Squadretta ad aggancio esterno | Corner with external clasping  
 Equerre a accrochage exterieur | Escuadra de agarre externo



Alu in alluminio pressofuso, vite M6 con rivestimento protettivo dacromet 320 e rondella in acciaio zincato, pulsanti in zama, molle in acciaio temprato.



Die-cast aluminium wings, galvanized steel M6 screw with protective Dacromet 320 coating and washer, zamak buttons, tempered steel springs.



Ailes en aluminium moulées sous pression, vis M6 avec revêtement de protection Dacromet 320 et rondelle en acier zingué, boutons en zamak, ressorts en acier zingué.



Alas de aluminio de fundición, tornillos M6 con revestimiento protector Dacromet 320 y arandela de acero galvanizado, botones de zamak, resortes de acero templado.



ART.	TUTTI   ALL TOUS   TODOS
Imballo   Package   Conditionnement   Embalaje	150 PZ
Finiture disponibili   Available finishes Finitions disponibles   Acabados disponibles	1 2 3 4 5 6

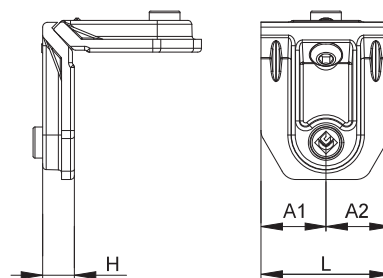
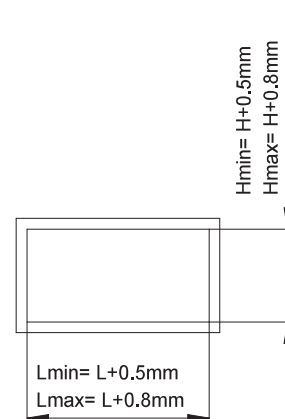
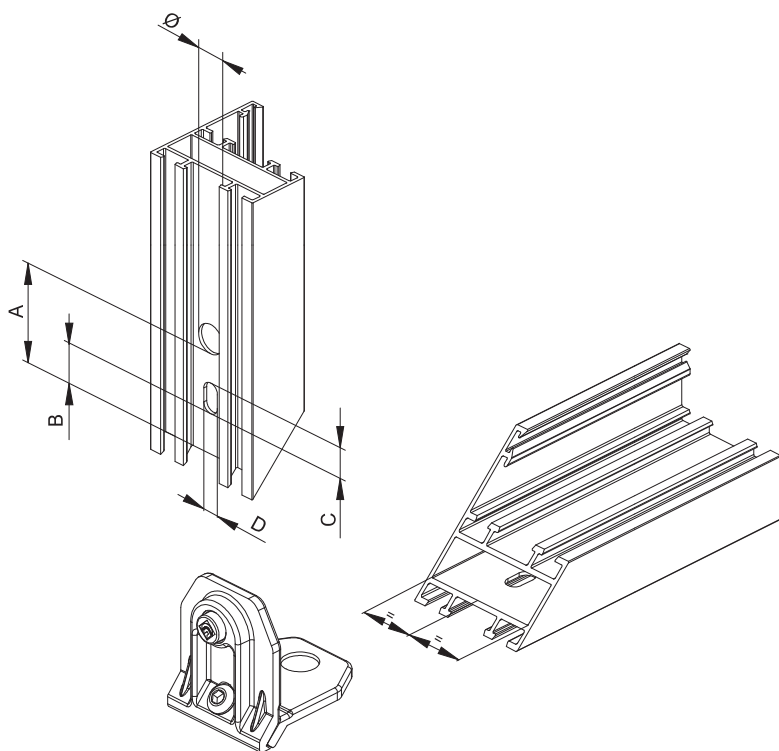

ART.	L	H	Ø	A	B	C	D	A1	A2	CH
0339 #	13,7	11,8	8	39	17	11	6	=	=	4
0368	14	13,5	8	38	14	14	6	=	=	4
0357	15,3	8,2	9,5	33	11	11	6	=	=	4
0317	16,5	13,4	10,5	41	14	18	6	=	=	4
0369	16,5	10,3	10,5	38	12	18	6	=	=	4
0338 #	16,8	14,3	10,5	41	21	11	6	=	=	5
0338,1 #	16,8	14,3	8	42	21	11	6	=	=	5
0337	19	10,5	10,5	37	12	11	6	=	=	4
0364	20,5	10,3	10,5	36	14,5	11	6	=	=	4
0333	22	10,5	10,5	37	12	11	6	=	=	4
0358	21,9	8,2	9,5	33	11	11	6	=	=	4
0332	23	14	10,5	41	21	11	6	=	=	5
0314	23,9	14	10,5	41	22	11	6	=	=	5
0344	23,9	26	10,5	41	18,5	14	6	=	=	5
0331	24	10,5	10,5	37	12	11	6	=	=	4
0319	25	8,1	9,5	35	12,5	11	6	=	=	4
0340	25,2	17	10,5	41	22	11	6	=	=	5
0313	25,8	9,9	8	37,5	14,5	11	6	=	=	4
0363	26,1	10,5	10,5	36,5	14,5	11	6	=	=	4
0352	28	12	10,5	38	15,5	11	6	=	=	4
0362	28,4	10,6	10,5	36,5	14,5	11	6	=	=	4
0335	28,5	14,5	10,5	41	21	11	6	=	=	5
0361,1 DX	28,6	14	10,5	36,5	14	11	6	10,4	18,2	4
0361,2 SX	28,6	14	10,5	36,5	14	11	6	18,2	10,4	4
0367	31,9	10,3	10,5	38	12	11	6	=	=	4
0315	32	17,4	10,5	39	21	11	6	=	=	5
0356	32	10,6	10,5	36,5	14,5	11	6	=	=	4
0355,1	35,4	10,6	8	37,5	14,5	14	6	=	=	4
0355	35,4	10,6	10,5	36,5	14,5	11	6	=	=	4
0359	35,6	8,2	9,5	33	11	11	6	=	=	4
0334	35,8	13,5	10,5	41	21	11	6	=	=	5
0334,1 #	35,8	13,5	10,5	41	21	11	6	=	=	5
0334,2	35,8	13,5	8	42	14,5	14	6	=	=	5
0343	35,8	14,7	10,5	41	21	11	6	=	=	5
0345	35,8	24	10,5	41	20	11	6	=	=	5
0348	35,8	30,5	10,5	41	21	11	6	=	=	5
0350	35,8	35	10,5	41	21	11	6	=	=	5
0365	35,8	14,3	10,5	41	21	11	6	=	=	5
0342	35,9	9,9	10,5	36	11	11	6	=	=	4
0346	35,8	24,8	10,5	40	21	11	6	=	=	5
0349	35,8	29,2	10,5	41	21	11	6	=	=	5
0353	35,8	15,5	8	41	20	11	6	=	=	5
0351,2	37	13,8	10,5	41	21	11	6	13,8	23,2	5
0312,1 DX	37	15,7	10,5	39,8	20	11	6	22,3	14,7	5
0312,2 SX	37	15,7	10,5	39,8	20	11	6	14,7	22,3	5
0311	40,5	9,9	10,5	36	14,5	11	6	=	=	4

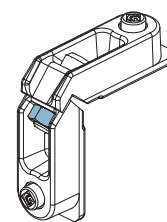

# con dado | with nut